



Producto distribuido por

SDM
Oil & Gas

 (+51) 999 012777  ventas@sdm.pe

www.sdm.pe | Av. Galvez Barrenechea 274. San Isidro

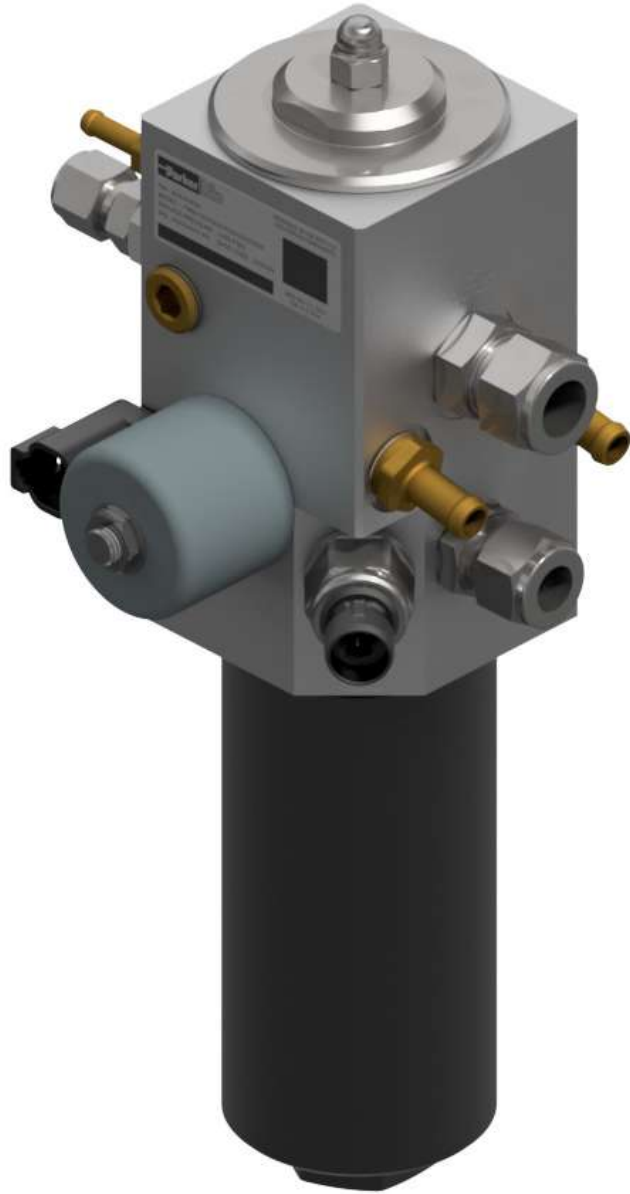

FM80 / FM80E Technical Bulletin

CNG Fuel Regulation Module



ENGINEERING YOUR SUCCESS.

Index

Applications	3
Function & System Design	4
Customer Benefits.....	6
Specifications	7
Media Gas & Coolant Flow	8
Electrical and Electronic Components.....	11
Installation Conditions.....	12
Environment.....	13
Mechanical Construction	14
Certificates and Approvals.....	16
Ordering Information	17
Options, Accessories, & Replacement Parts.....	18
Model Configuration Guide.....	22

Throughout this guide, the term FM80 will refer to both:

1. FM80 regulators with CNG flow capacity of 176 lbs/hr [80 kg/hr]
2. FM80E regulators with CNG flow capacity of 198 lbs/hr [90 kg/hr]

The FM80 is optimally designed for 5 to 13 L engines.



FM80 Function

The FM80 is a configurable compressed natural gas (CNG) fuel regulation module designed for engines sizes of 5 to 13 liters. The FM80 design is optimized to maintain stable pressures and high flow to the downstream components across the full operating range of CNG vehicles (tank pressures of 3600 psig to 225 psig or 250 bar to 15 bar). The module body is made of durable anodized aluminum and incorporates a piston-style regulator with an integrated heat exchanger and pressure relief valve. The FM80 incorporates additional functional elements including a solenoid shut-off valve (on/off), a coalescing filter (available in various grades and sizes), and pressure sensors for both high and low pressure sides of the regulator.

The FM80 has superior flow pressure-characteristics compared to other products available in the market with a 20 psi (1.4 bar) delivery pressure envelope and superior overall system performance. Parker's proprietary poppet technology has proven reliable over millions of cycles and under the most extreme environmental conditions.



FM80 Design

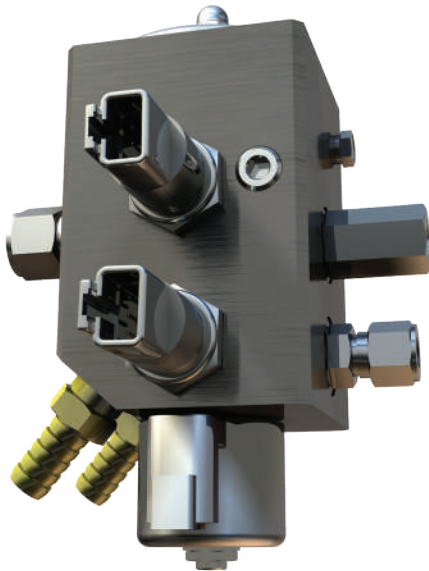

Regulation module

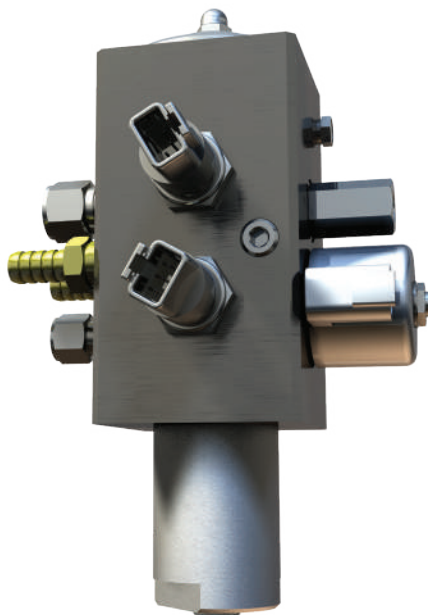

Regulation module with standard coalescing filter



Regulation module with large coalescing filter

FM80 Process Flow Diagrams

Regulation module with coalescing filter

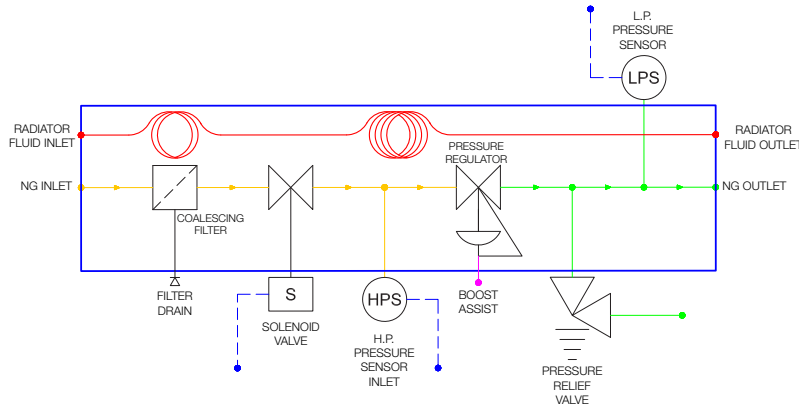

Regulation module with two-stage pressure regulation with coalescing filter

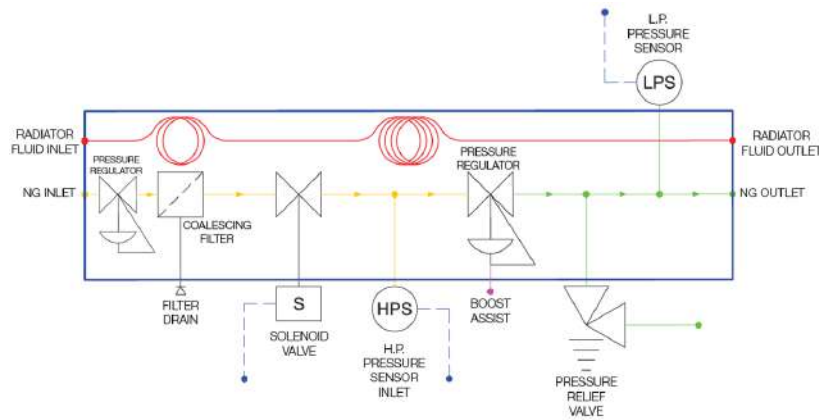

Regulation module without coalescing filter

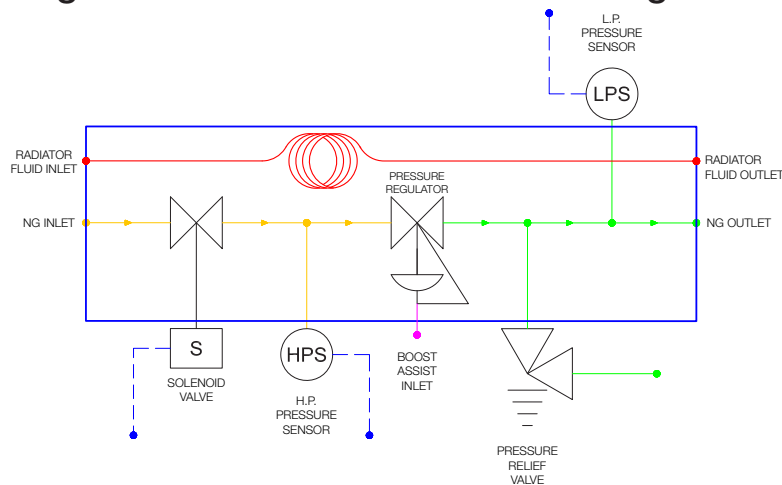

Regulator Design

The FM80's outlet pressure is factory set and may be tailored to the need of a specific application. The FM80 single-stage regulator design encompasses multiple advantages including:

- An Aluminum piston style outlet pressure sensing component that provides superior strength and environmental resistance;
- Proven high flow at low tank pressures while reducing leak points and minimizing resonance points;
- The proprietary dual aligned poppet, that provides for high performance of the dynamic seal over the product life;
- Full flow at lower tank cut off pressures resulting in longer driving distances between refueling; and
- Proprietary Parker low-temperature seal technology, developed specifically for compressed natural gas service, ensuring reliable operation in severe environmental conditions.

System Design Benefits

Heat exchanger design

*The FM80 heat exchanger design provides increased cold weather performance and increased heat distribution (compared to competitor regulators); both of which lead to lower risks for the OEM. There are no soft seals in the heat exchanger design and as a result, the FM80 eliminates risk of gas/coolant mixing, enhances reliability, and reduces unplanned system maintenance requirements. [FM80 models incorporate a best-in-class heat-exchanger including a pre-heating element in models with large filter.]

Integrated coalescent filter (option)

The FM80 design allows for the integration of a high pressure coalescent filter. The standard filter (0.5 oz sump) is ideal for light and medium duty applications. The large filter (5.0 oz sump) is ideal for heavy duty and high cycle applications. Each filter offers the option of filtering out 10 micrometer OD particles or 6 micrometer at 95% and 99.97% efficiencies, respectively.

FM80 Specifications

Operating Conditions	
Service Pressure	3,600 psig (P36) [250 bar]
Operating Temperature	-40°F to 248°F [-40°C to 120°C]
Media	Natural Gas
Performance	
Flow Capacity	198 lb/hr [90 kg/hr]
Leakage	Bubble Tight
Pressure Regulator	
Outlet Pressure Setpoint Option	58 to 140 psig [4.0 to 9.65 bar]
Nominal Outlet Pressure Envelope	+0/-20 psig (+0/-1.4 bar) from idle to full flow
Boost Pressure (Optional)	1:1 clean dry air to compressed natural gas ratio
Relief Valve	195 ± 35 psig [13.4 ± 2.4 bar] or 166 ± 14 psig [11.5 ± 1.0 bar]
Heat Exchanger	Radiator Fluid Circuit Standard
Interface / Connections	
Inlet Connection	#6 SAE Female
Outlet Connection	#8 SAE Female
Radiator Fluid Connection	3/8" NPT Female
Relief Valve Connection	#6 SAE Female
Filter Drain Connection	#6 SAE Female (plugged)
Electrical Requirements	
Input Voltage (Solenoid Valve)	12 V or 24 V
Nominal Current Requirements	1.7 A
Power (Solenoid Valve)	16 Watts
Connection Type (Solenoid Valve)	Deutsch Connector
Dimensions	
All Dimensions	Consult "Mechanical Construction"

Gas Flow

Gas Composition & Characteristics

The FM80 is designed to function with Natural Gas complying with the Recommended Practice for Compressed Natural Gas Vehicle Fuel, SAE J1616, or CGSB 3.513, or an equivalent national Standard. The FM80 should not be introduced to gas that has had methanol or glycol deliberately added at the fuel station.

Flow Curves

The FM80 is designed to maintain acceptable downstream (fuel rail) pressure at flow rates up to 198 lb/hr [90 kg/hr]. It is also designed to maintain acceptable downstream (fuel rail) pressures at low tank fuel levels, leading to extended vehicle range. Performance curves for the FM80 under various inlet pressure flow conditions are shown below.

FM80 Flow Performance Curves

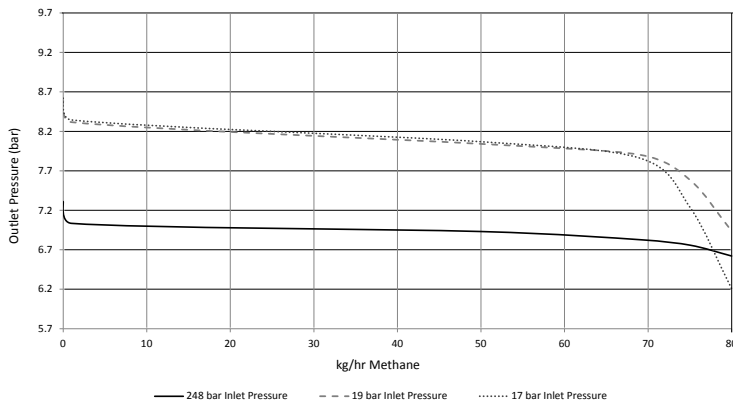

Figure 1. FM80 Typical Flow Curve (kg/hr)

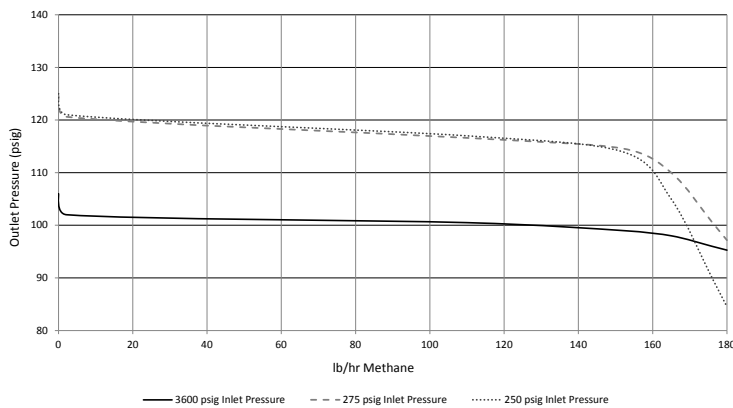

Figure 2. FM80 Typical Flow Curve (lb/hr)

Performance for various configurations at low fuel tank levels are shown below. Note that gas flow is a function of gas composition (see section titled "Gas Composition & Characteristics").

Regulator with No Filter and No Solenoid

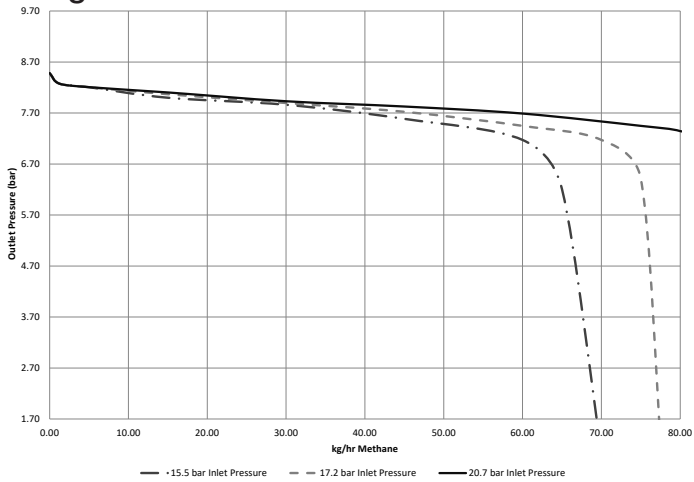

Figure 3. FM80 Typical Flow Curve :
Low Tank Pressure, No Filter / No Solenoid (kg/hr)

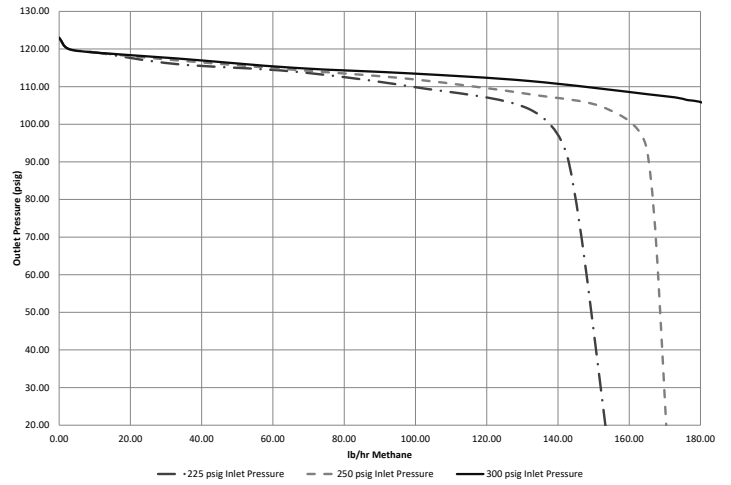

Figure 4. FM80 Typical Flow Curve :
Low Tank Pressure Flow, No Filter / No Solenoid (lb/hr)

Regulator with Standard (0.5 oz) Filter and No Solenoid

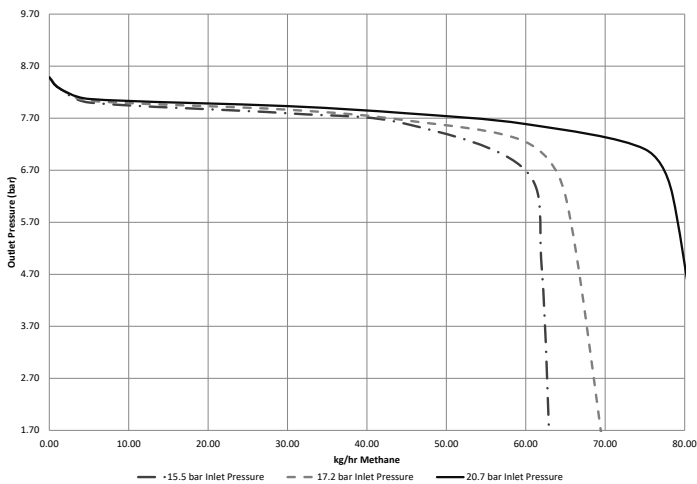

Figure 5. FM80 Low Tank Pressure Flow,
0.5 oz Filter / No Solenoid (kg/hr)

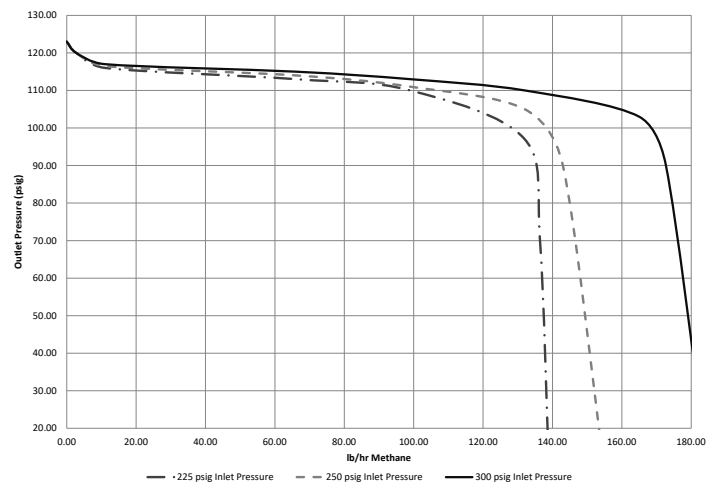

Figure 6. FM80 Low Tank Pressure Flow,
0.5 oz Filter / No Solenoid (lb/hr)

Regulator with Standard (0.5 oz) Filter and Solenoid

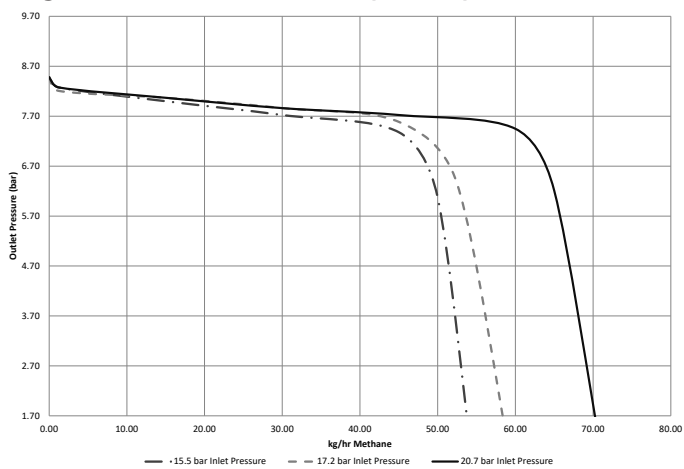

Figure 7. FM80 Low Tank Pressure Flow,
0.5 oz Filter / Solenoid (kg/hr)

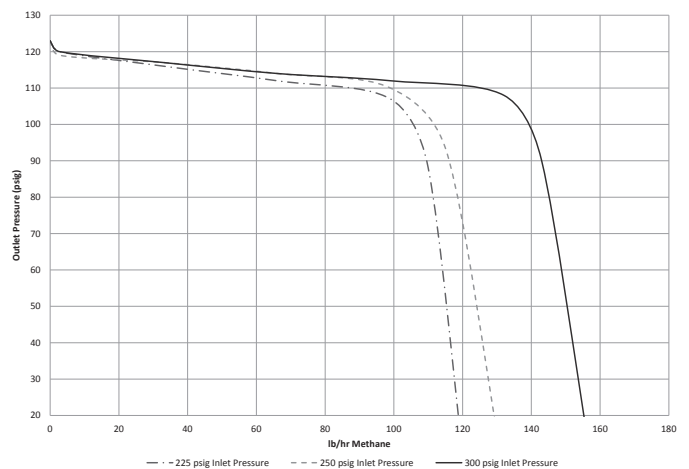

Figure 8. FM80 Low Tank Pressure Flow,
0.5 oz Filter / Solenoid (lb/hr)

Regulator with Large (5 oz) Filter and Solenoid

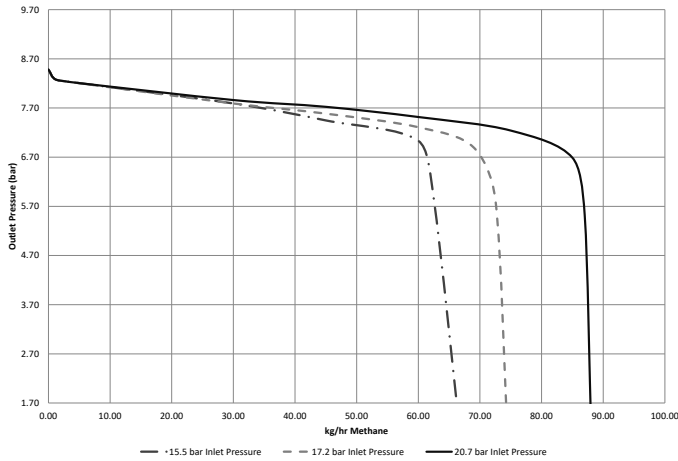

Figure 9. FM80 Low Tank Pressure Flow, 5.0 oz Filter / Solenoid (kg/hr)

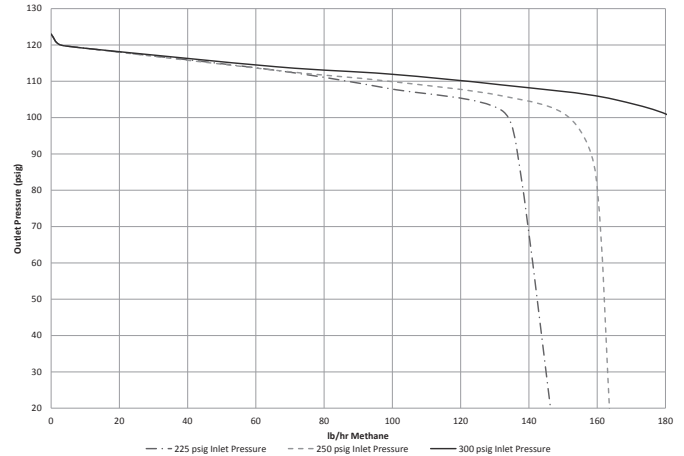

Figure 10. FM80 Low Tank Pressure Flow, 5.0 oz Filter / Solenoid (lb/hr)

Boost Pressure Augmentation

The FM80 outlet pressure can be augmented with an optional boost pressure system. The system is designed for use only with clean dry air (CDA). This system must be specified upon ordering. When selecting the boost pressure augmentation option, consult the factory for regulator outlet pressure setting.

Coolant Flow

Coolant Composition & Characteristics

The FM80 is designed to function only with radiator fluid (50/50 coolant/water ratio) flowing through the heat exchanger fluid circuit. For applications not containing radiator fluid, contact the factory for alternate solution.

Attribute	Coolant Specification
Minimum Coolant Flow Rate	1 gpm (0.06 L/s)

Input(s)

Solenoid Valve

The solenoid valve integrated within the FM80 may operate on either 12VDC or 24VDC power (depending on configuration), providing compatibility with most current vehicle electrical systems. The FM80 can be integrated and controlled using the vehicle power and control systems. There is no need to install alternative power adapters to use the FM80.

The Deutsch solenoid coils have Deutsch DT04-2P connections which mate with DT06-2S connections.

Output(s)

High Pressure Sensor

The high pressure sensor measures the pressure at the inlet of the FM80, representative of the pressure of the board storage tank.

The pressure sensors have Deutsch DTM04 - 3P connection which mate with Deutsch DTM06 - 3S connections.

Low Pressure Sensor

The low pressure sensor measures the pressure of the fuel at the outlet of the FM80, representative of the fuel rail pressure.

The pressure sensors have Deutsch DTM04 - 3P connection which mate with Deutsch DTM06 - 3S connections.

The FM80 can be mounted with M8 bolts. The FM80 cannot be mounted by gas or coolant connections.

Orientation (Configuration Specific)

No Coalescing Filter

The FM80 with No Coalescing Filter should be mounted with the regulator axis positioned vertically.

With Coalescing Filter

The FM80 with filter (0.5 oz, 3 oz, and 5 oz options) must be mounted with the filter drain down as indicated below:

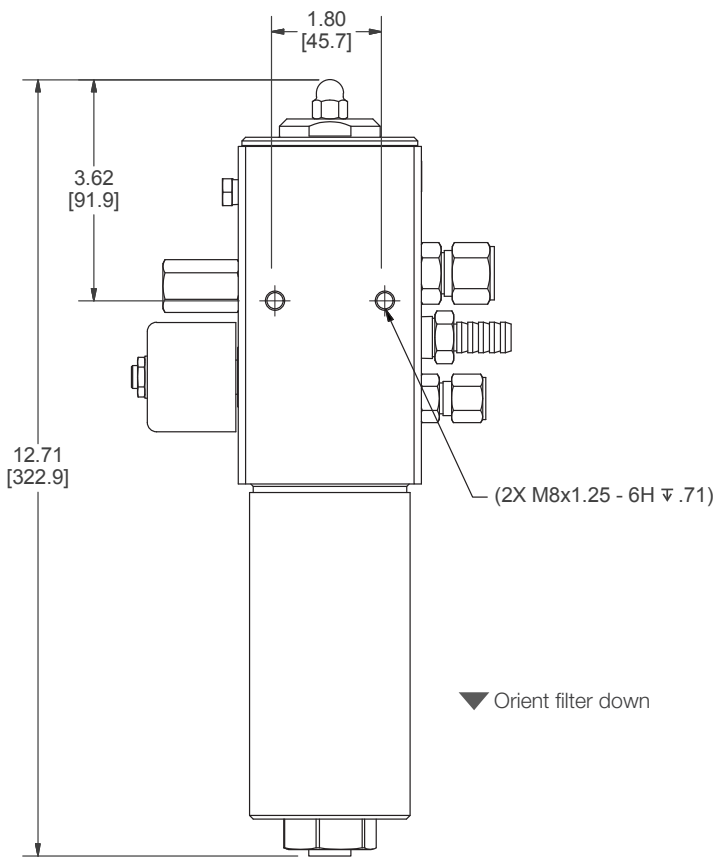

Figure 11.
FM80 with 5.0 oz Filter Sump and SOV

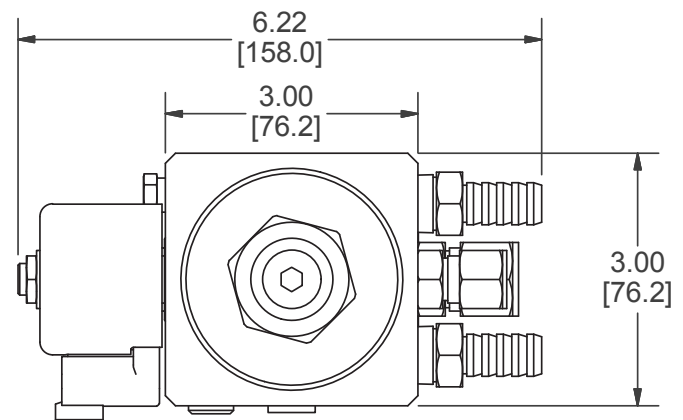

Figure 12.
View from Bottom

Note: For configurations with solenoid valve and/or filter, consider clearances required for maintenance.

- Vertical height of 0.5 oz filter is 2.72 in (69.09 mm)
- Vertical height of 3 oz filter is 6.47 in (164.34 mm)

System Requirements:

NGV 3.1 recommends that natural gas systems contain pressure relief valves (PRV).

The FM80 incorporates a PRV and should be operated with the PRV intact. If the PRV is removed from an assembled unit, full function or safety cannot be guaranteed.

If the application does not require an integrated PRV, consult the factory for options.

Temperature

The FM80 operates optimally within -40°F and +248°F [-40°C and +120°C].

Safety / Installation Considerations

All FM80 units are factory preset. Changing the pressure setting can cause unexpected and/or potentially hazardous operation. Outlet pressure settings are to be determined at order placement.

The FM80 pressure relief valve (PRV) is not a high flow device and may not protect the FM80 or fuel system in case of sudden failure.

Consult the FM80 Installation, Operation and Maintenance Manual (Document Number: IOM7224) for further information.

FM80 Body Materials

Component	Material
Body	Anodized Aluminum
Filter Housing	Anodized Aluminum
Inlet & Outlet Gas Fittings	Stainless Steel
Heat Exchanger Barb Fittings	Brass
Dome Load Barb Fittings	Stainless Steel
Seal	Fluorocarbon, Peek®
Poppet	Stainless Steel

Design Dimensions

FM80 with No Coalescing Filter

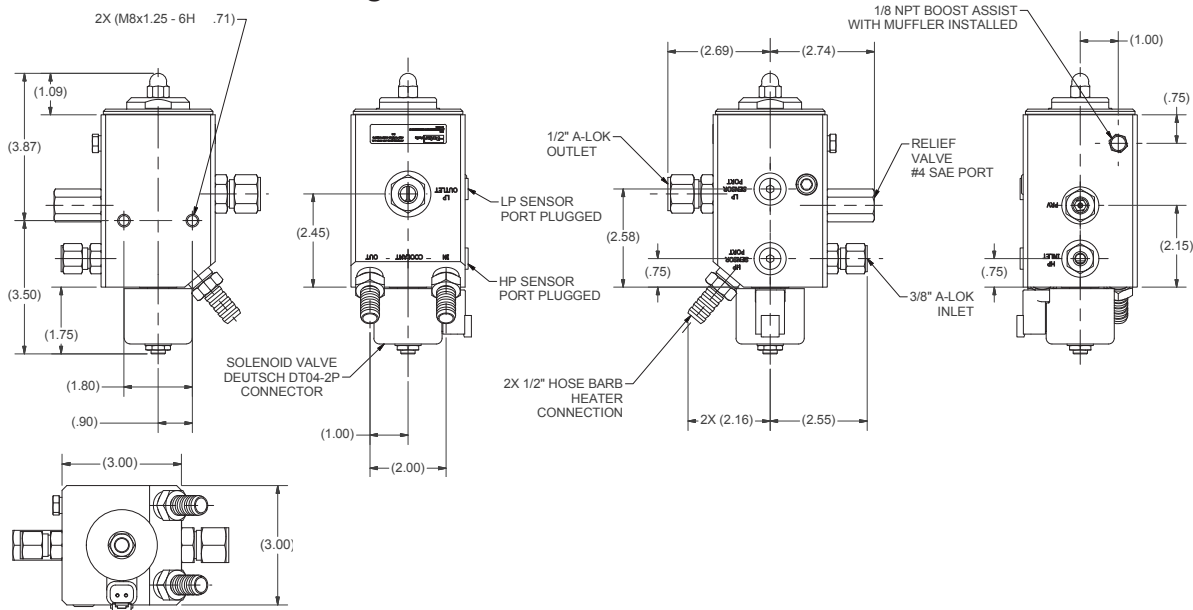

FM80 with Standard Coalescing Filter (0.5 oz)

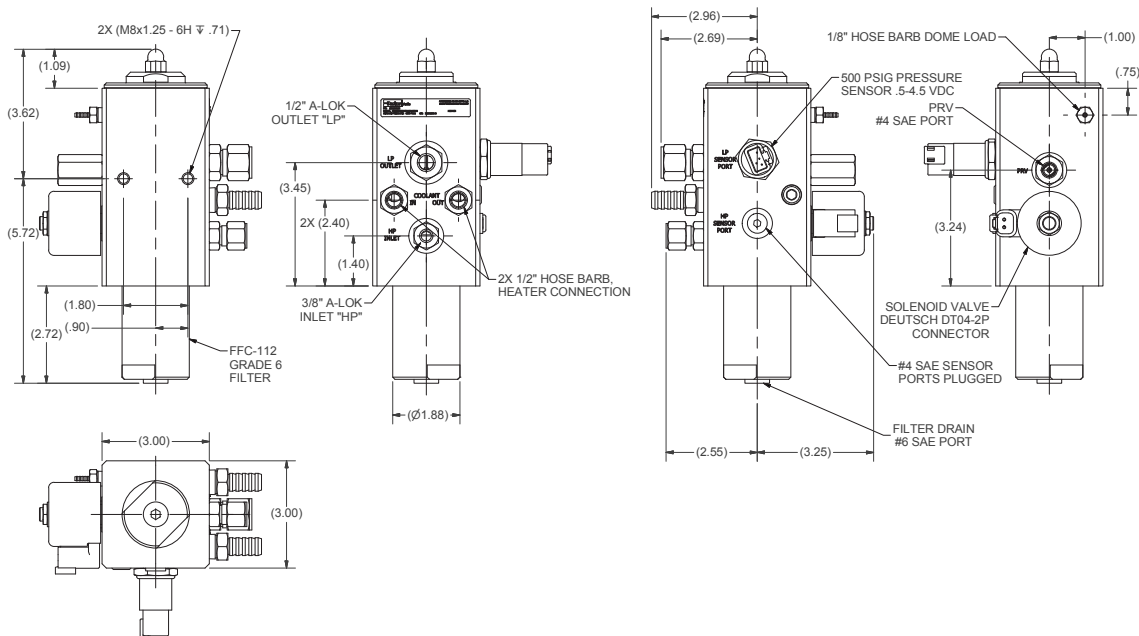

FM80 with Large Coalescing Filter (5 oz)

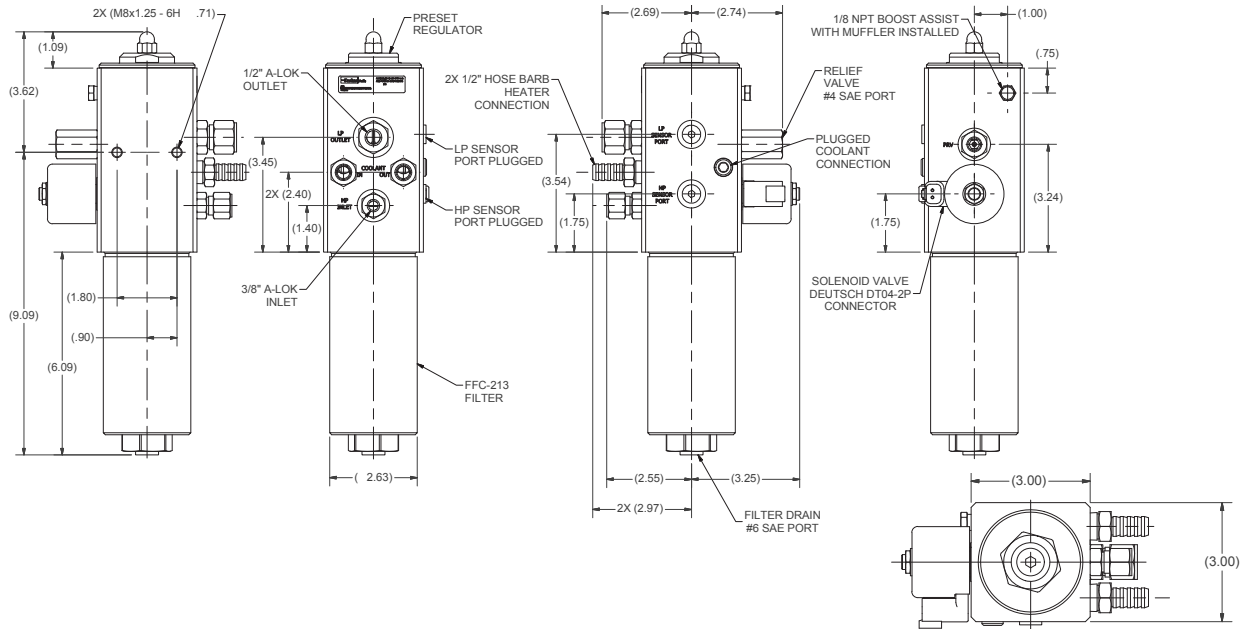

FM80E with Large Coalescing Filter, 2-Stage Pressure Reduction, and SOV

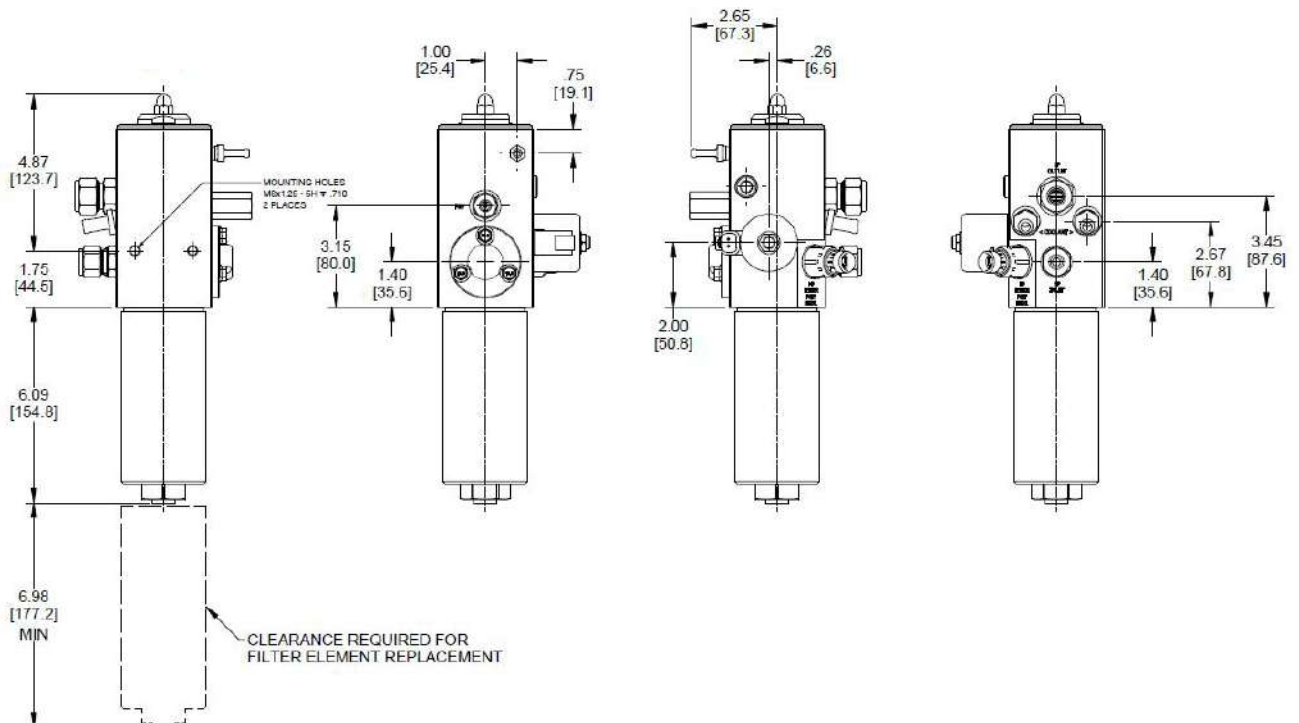

Applicable Code, Standard or Advisory	Applicability	FM80 Status
CSA/ANSI NGV3.1, 2014	This American standard establishes requirements for newly produced CNG fuel system components, intended for use on NGVs.	Certified
ECE R110	This regulation, issued by the United Nations, considers all of the components in the fueling system of NGVs. This document is used to regulate NGV system components in the European Union, Brazil, Argentina, and other countries.	Certified
IATF 16949	This Automotive QMS standard, with ISO 9001 and customer specific requirements, defines the fundamental quality management system requirements for automotive production and relevant service parts organizations.	Certified
In Metro	This Latin America standard establishes requirements for CNG fuel system components.	Certified

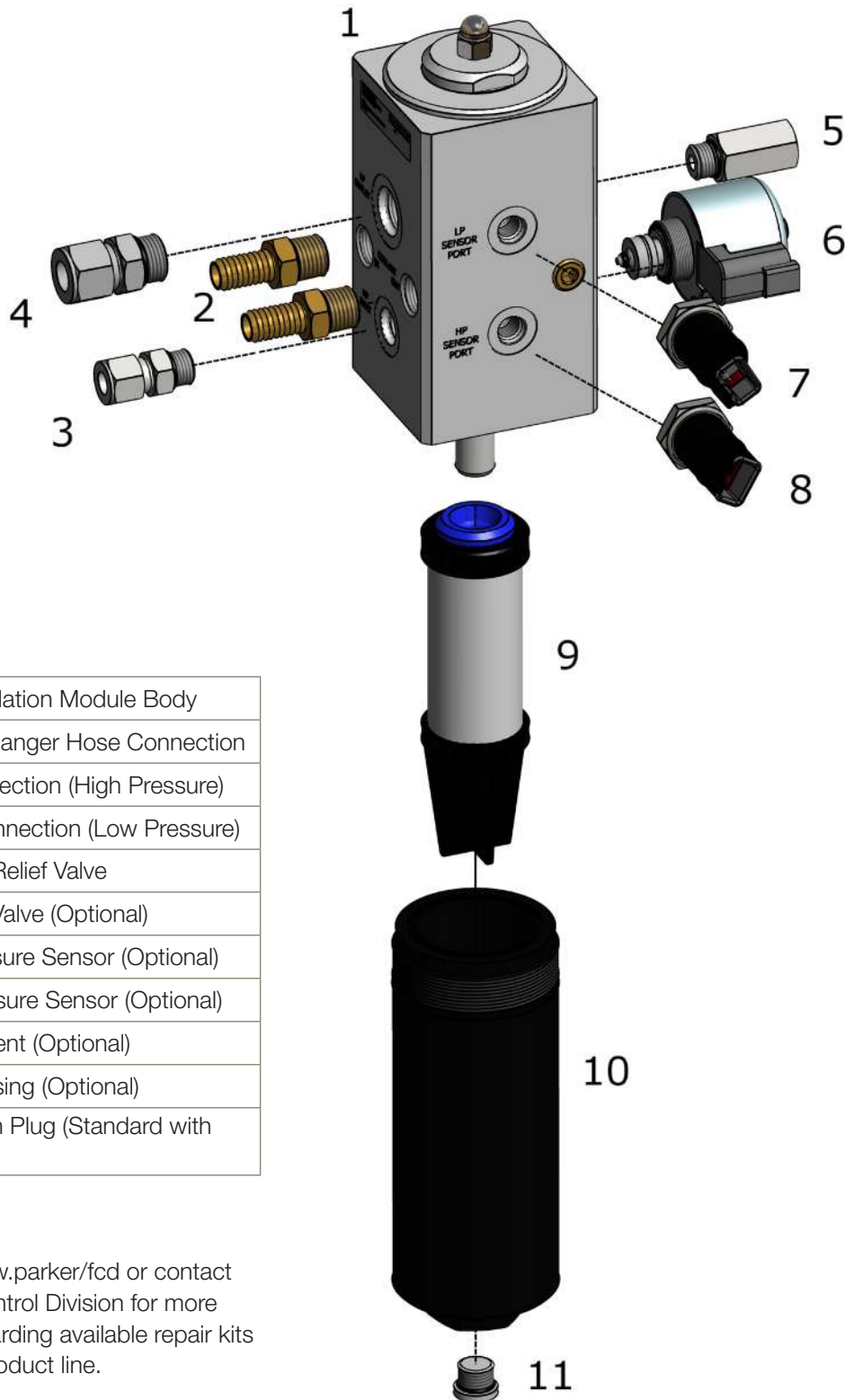

1	Fuel Regulation Module Body
2	Heat Exchanger Hose Connection
3	Inlet Connection (High Pressure)
4	Outlet Connection (Low Pressure)
5	Pressure Relief Valve
6	Solenoid Valve (Optional)
7	Low Pressure Sensor (Optional)
8	High Pressure Sensor (Optional)
9	Filer Element (Optional)
10	Filter Housing (Optional)
11	Filter Drain Plug (Standard with any Filter)

Please visit www.parker/fcd or contact Parker Fluid Control Division for more information regarding available repair kits for the FM80 product line.

Coalescer / Filter

The standard and large high pressure filters are designed to protect critical NGV engine components. Contaminants may be introduced into the vehicle's fuel tank during fueling. Possible sources of contamination include compressor oil, pipe scale, and (metallic or organic) particles. The coalescing filters offered as part of the FM80 are specifically designed to remove oil, water and solid contaminants from CNG. Filter selections will be dependent on application, engine size, and gas quality.

It is recommended to drain the filter housing every 2000 miles (40 hours) on the standard filter, and every 4000 miles (80 hours) on the large filter or as necessary. It is also recommended to replace FM80 filter elements at 6000 miles (120 hours) with the standard filter and 12000 miles (240 hours) with the large filter.

Please visit www.parker/fcd or contact Parker Fluid Control Division for more information regarding available repair kits for the FM80 product line.

Maintenance intervals are dependent on gas quality, system, and driving conditions.

If the FM80 is ordered without a coalescing filter, Parker requires that a Grade 10 or better high pressure coalescing filter be installed upstream of the unit.

Made by Parker Hannifin Gas Separation & Filtration Division, the filters used within the FM80 are specified to meet the following conditions:

Attribute	0.5 Filter oz Specification	5 oz Filter Specification
Drain port size	3/8" SAE	3/8" SAE
Service pressure	3600 psi (248 bar)	3600 psi (248 bar)
Temperature range	-40°F to +248°F (-40°C to +120°C)	-40°F to +248°F (-40°C to +120°C)
Bowl material	Anodized aluminum	Anodized aluminum
Seals	VG109-90 (FKM)	VG109-90 (FKM)
Sump capacity	0.5 oz (14.8 cc)	5.0 oz (148 cc)

Solenoid Valve

Designed by Parker Hannifin Fluid Control Division, the solenoid valves used within the FM80 are specified to meet the following conditions:

Attribute	12 VDC Deutsch	24 VDC Deutsch
Operating pressure differential	0 to 4500 psig	0 to 4500 psig
Temperature range	-40°F to 356°F [-40°C to +180°C]	-40°F to 356°F [-40°C to +180°C]
Power	16 watts	16 watts
Current draw	1.606 A to 0.889 A [Up to 70°F/ 121°C]	0.803 A to 0.445A [Up to 70°F / 121°C]
Seal materials	Low temperature FKM	Low temperature FKM

Boost Pressure Fittings

Designed by Parker Instrumentation Products Division, the bias pressure fitting is designed as a leak-free connection for CNG applications. The bias pressure barb fittings are designed to meet the following conditions:

Attribute	1/8" Hose Barb Specification	3 mm Hose Barb Specification
Basic fitting material	Stainless steel (Type 316)	Stainless steel (Type 316)
Bar stock	ASME-SA-479 (Type 316-SS)	ASME-SA-479 (Type 316-SS)
Forging	ASME-SA-182 F316	ASME-SA-182 F316

Pressure Sensor

0.5 – 4.5 V Specifications [Example]

Attribute	High Pressure	Low Pressure
Operating pressure	5000 psi (344.7 bar)	500 psi (34.5 bar)
Pressure sensing mode	Ratiometric	Ratiometric
Zero output	0.5 Vdc	0.5 Vdc
Full scale span	0.5 Vdc to 4.5 Vdc	0.5 Vdc to 4.5 Vdc
Excitation	5 Vdc (6 Vdc max.)	5 Vdc (6 Vdc max.)
Supply current	4 mA typ. (8 mA max.)	4 mA typ. (8 mA max.)
Accuracy (max%)	± 0.25%	± 0.25%
Termination style	Deutsch DTM04-3P (Integral)	Deutsch DTM04-3P (Integral)
Operating temperature	-40°F to 257°F [-40°C to 125°C]	-40°F to 257°F [-40°C to 125°C]

All specifications are at 77°F [25°C] and at rated excitation unless otherwise specified. Parker Hannifin's Fluid Control Division maintains the right to select a manufacturer of their choosing. Alternate specifications available upon request.

4 mA - 20 mA Specifications [Example]

Attribute	High Pressure	Low Pressure
Operating pressure	5000 psi [344.7 bar]	500 psi [34.5 bar]
Pressure sensing mode	Gage	Gage
Zero output	4 mA	4 mA
Full scale span	4 mA to 20 mA	4 mA to 20 mA
Excitation	9.5 Vdc to 30 Vdc	9.5 Vdc to 30 Vdc
Supply current	N/A	N/A
Accuracy (max%)	± 0.25%	± 0.25%
Termination style	Deutsch DTM04-3P (Integral)	Deutsch DTM04-3P (Integral)
Operating temperature	-40°F to 257°F [-40°C to +125°C]	-40°F to 257°F [-40°C to +125°C]

All specifications are at 77°F [25°C] and at rated excitation unless otherwise specified. Parker Hannifin's Fluid Control Division maintains the right to select a manufacturer of their choosing. Alternate specifications available upon request.

Inlet & Outlet Connections

Seal-Lok™

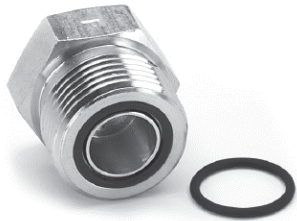

The Seal-Lok™ fittings meet or exceed the strict requirements of SAE J1453 and ISO 8434-3. Seal-Lok is an O-Ring face seal type fitting that consists of a nut, a body, and an O-Ring with a sleeve. When the fitting is assembled, it compresses an O-Ring into the precision machined groove of the fitting body to form a leak tight seal. Manufactured by Parker Hannifin Tube Fittings Division, the Seal-Lok light duty SAE fittings are designed to meet the following conditions:

Attribute	1/2" Fitting	3/8" Fitting	8 mm Fitting	12 mm Fitting
Basic fitting material	Stainless steel (300 Series)	Stainless steel (300 Series)	Stainless steel (300 Series)	Stainless steel (300 Series)
Connection type	O-Ring Face Seal	O-Ring Face Seal	O-Ring Face Seal	O-Ring Face Seal
O-Ring material	VG109-90 low temperature FKM O-Ring	VG109-90 low temperature FKM O-Ring	VG109-90 low temperature FKM O-Ring	VG109-90 low temperature FKM O-Ring

A-LOK®

Parker A-LOK® fittings are designed as leak-free connections for a vast range of applications. The Parker A-LOK fitting features the Supercase II hardened ferrule to provide superior corrosion resistance. The FM80 fittings are two ferrule fittings, manufactured to the highest quality standards. Manufactured by Parker Hannifin Instrumentation Products Division, the A-LOK light duty SAE fittings are designed to meet the following conditions:



Attribute	1/2" Fitting	3/8" Fitting	8 mm Fitting	12 mm Fitting
Basic fitting material	Stainless steel (Type 316)	Stainless steel (Type 316)	Stainless steel (Type 316)	Stainless steel (Type 316)
Connection type	Compression, two ferrule light duty SAE threads	Compression, two ferrule light duty SAE threads	Compression, two ferrule light Duty SAE threads	Compression, two ferrule light duty SAE threads
O-Ring material	VG109-90 low temperature FKM O-Ring	VG109-90 low temperature FKM O-Ring	VG109-90 low temperature FKM O-Ring	VG109-90 low temperature FKM O-Ring

Heat Exchanger Hose Connections

Parker Instrumentation Tube Fittings seal equally well on both thin wall and heavy wall tubing. Manufactured by Parker Hannifin Instrumentation Products Division, the heat exchanger hose barb fittings are specified to meet the following conditions:

Attribute	1/2" Hose Connection	1/4" Hose Connection	12 mm Hose Connection	6 mm Hose Connection
Basic fitting material	Brass	Brass	Brass	Brass
Connection type	Compression, two ferrule light duty SAE threads	Compression, two ferrule light duty SAE threads	Compression, two ferrule light duty SAE threads	Compression, two ferrule light duty SAE threads

Special Accessories

Special accessories can be made available via “custom kits” upon request. These kits are subject to separate purchasing, certifications, and lead times.



Parker Hannifin Corporation

Fluid Control Division

95 Edgewood Avenue

New Britain, CT 06051

phone 860 827 2300

www.parker.com/fcd

www.parker.com/alternative-fuel