



Producto distribuido por

SDM
Oil & Gas

 (+51) 999 012777  ventas@sdm.pe

www.sdm.pe | Av. Galvez Barrenechea 274. San Isidro

CRYOGENIC RECIPROCATING PUMPS VT-3 SERIES FOR INDUSTRIAL GASES

TECHNICAL FEATURES

- Compatible with Cold Converter and Thermosyphon storage tanks
- Modular assembly (from Simplex to Triplex)
- High efficiency
- Low operating noise
- Quick maintenance thanks to the integrated cartridge seal system

APPLICATIONS

- Cylinders filling and high pressure accumulation capacities
- Other industrial applications

CRANKDRIVE SYSTEM

- TW 10 – Oil Lubrication

TRANSFERRED FLUIDS

- LIN, LOX, LAR, LCO₂, LN₂O

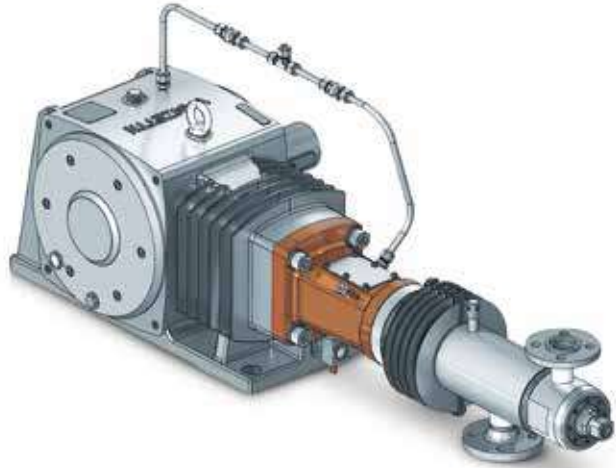

VT-3 TW 10 PERFORMANCES

Model	Piston		Flow-rate				Maximum allowable suction pressure (MASP)		Maximum allowable working pressure (MAWP)		Power installed
	Bore	Stroke	Min 150 rpm*		Max 380 rpm						Referred to MAWP
Series pump	mm	mm	lpm	gpm	lpm	gpm	bar	psi	bar	psi	kW
VT-3 55 62 S	55	62	20	5,3	50	13,2	20	290	320	4641	30 - 75
VT-3 55 62 D	55	62	40	10,6	100	26,4	20	290	320	4641	37 - 90
VT-3 55 62 T	55	62	60	15,9	150	39,6	20	290	320	4641	45 - 110
VT-3 60 62 S	60	62	23,7	6,3	60	15,9	20	290	320	4641	30 - 75
VT-3 60 62 D	60	62	47,3	12,5	120	31,7	20	290	320	4641	45 - 110
VT-3 60 62 T	60	62	71,0	18,8	180	47,6	20	290	320	4641	55 - 132

*Flow-rate can be reduced by forced oil lubrication system

NPSH required: 1,5 - 1,7 m

Data can be subjected to change

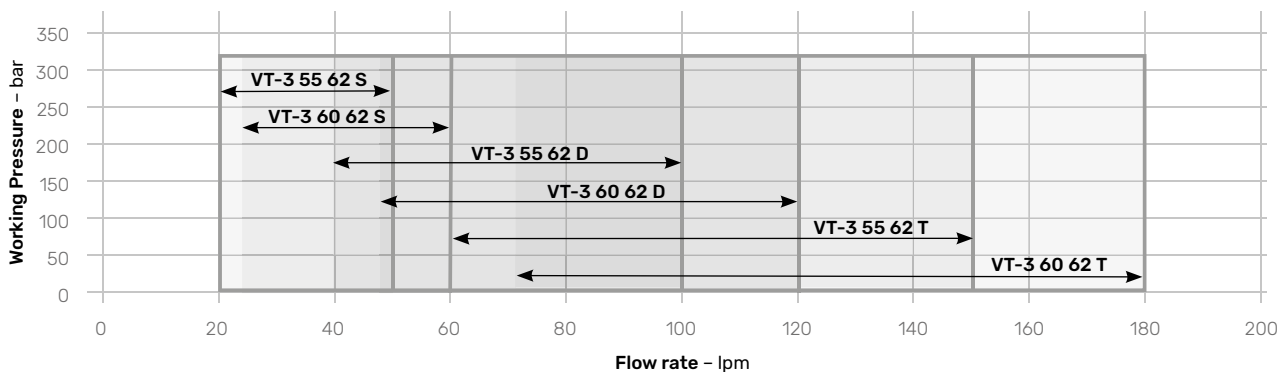

STANDARD SUPPLY

- Painted steel frame
- Cryogenic pump
- Electric motor
- Transmission by belt and pulleys or gearbox and couplings
- Double pulsation damper

STANDARD ACCESSORIES

- Suction flexible hose
- Return flexible hose
- Low pressure safety valve
- High pressure safety valve
- Check valve
- Pressure gauge
- Pressure switch
- Temperature sensor for cool down
- Temperature sensor for cavitation
- Temperature sensor for leaks detection
- Junction box

OPTIONAL ACCESSORIES

- Flushing system with nitrogen gas
- Forced oil lubrication system
- High pressure pneumatic valve for venting
- Motor suitable for VFD
- Complete automatic system available on demand

Average SKID weight: 1600 kg

Package overall dimensions: 295 x 118 x 154 cm

TEST AND CHECKS

- Dimensional control of each mechanical component before assembly
- Performance test with LIN available for class and customer

STANDARDS

Designed according to:

- European Directive Machinery
- European Directive PED
- EIGA/IGC/CGA guidelines

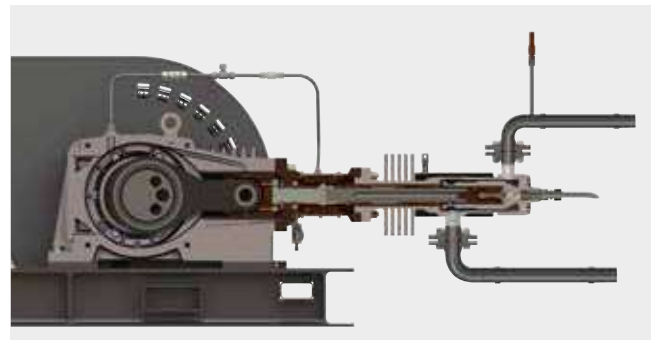

Pump skid section

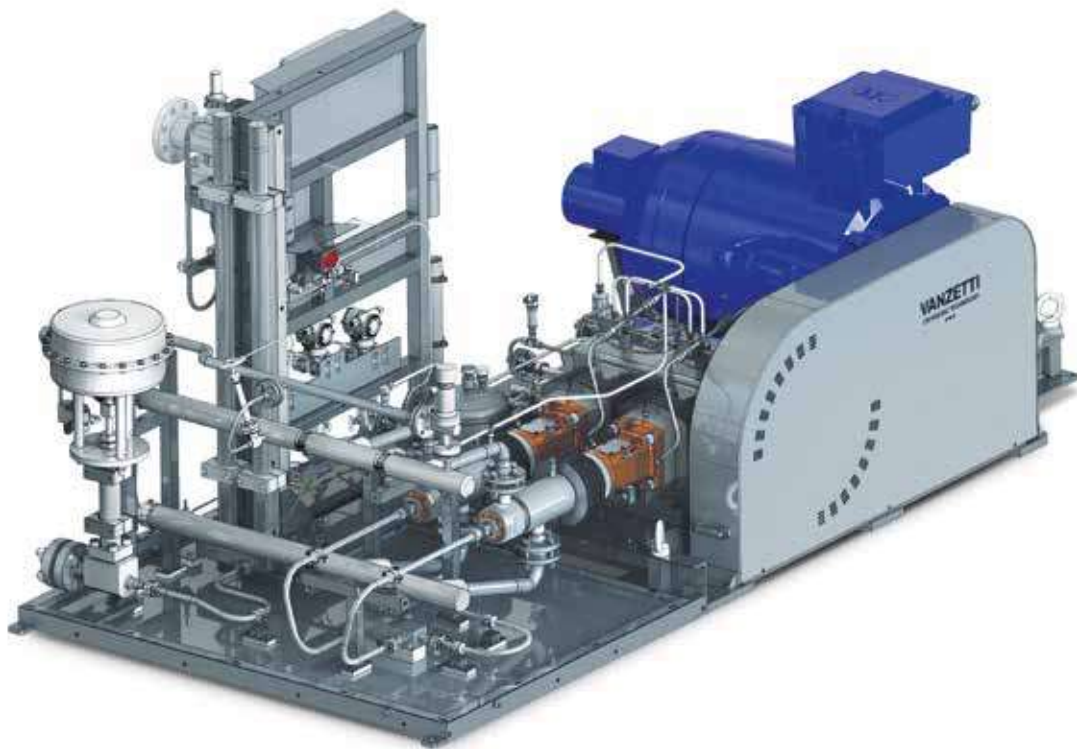

Certified quality management system