



Producto distribuido por

**SDM**  
Oil & Gas

 (+51) 999 012777  [ventas@sdm.pe](mailto:ventas@sdm.pe)

[www.sdm.pe](http://www.sdm.pe) | Av. Galvez Barrenechea 274. San Isidro

CRYOGENIC RECIPROCATING PUMPS

# HP SERIES

FOR INDUSTRIAL GASES

**TECHNICAL FEATURES**

- Compatible with Cold Converter and Thermosyphon storage tanks
- Low operating noise
- High reliability

**APPLICATIONS**

- Cylinders filling and high pressure accumulation capacities

**CRANKDRIVE SYSTEM**

- TW 3 – Grease Lubrication

**TRANSFERRED FLUIDS**

- LIN, LOX, LAR

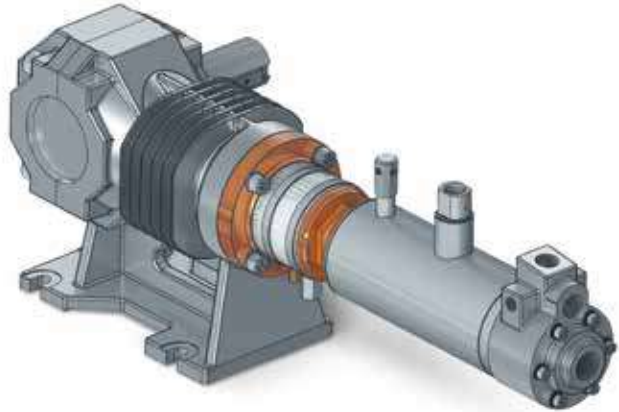

**HP TW 3 PERFORMANCES**

Model	Piston		Flow rate				Maximum allowable suction pressure (MASP)		Maximum allowable working pressure (MAWP)		Power Installed
	Bore	Stroke	Min 80 rpm		Max 420 rpm						Referred to MAWP
Series pump	mm	mm	lpm	gpm	lpm	gpm	bar	psi	bar	psi	kW
HP 25 20	25	20	0,7	0,2	3,5	0,9	16	232	420	6092	2,2 – 7,5
HP 25 32	25	32	1,1	0,3	5,6	1,5	16	232	420	6092	2,2 – 11
HP 30 20	30	20	1,0	0,3	5,0	1,3	20	290	300	4351	2,2 – 7,5
HP 30 32	30	32	1,6	0,4	8,0	2,1	20	290	300	4351	2,2 – 11
HP 36 20	36	20	1,4	0,4	7,2	1,9	20	290	300	4351	2,2 – 11
HP 36 32	36	32	2,3	0,6	11,6	3,1	20	290	300	4351	3 – 15

NPSH required: 1,5 – 1,7 m

Data can be subjected to change

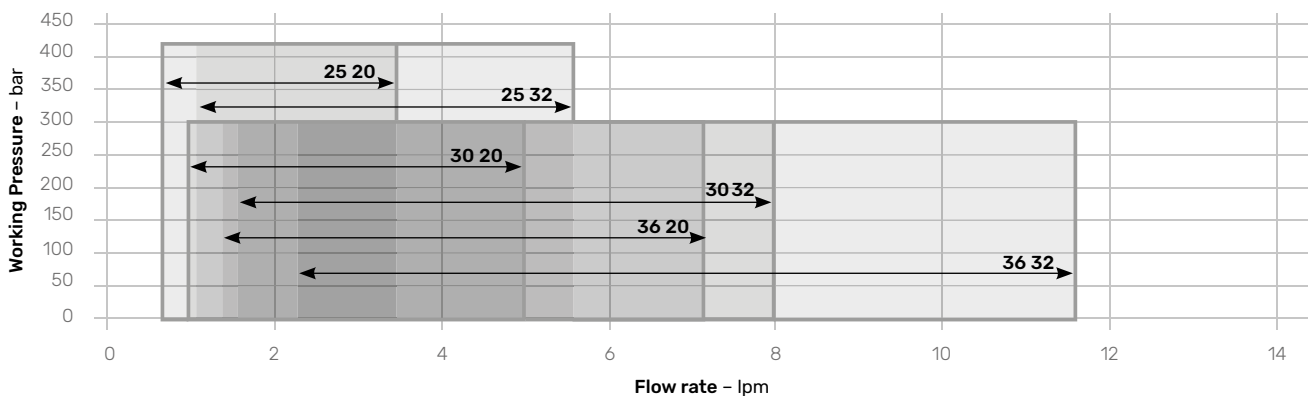

**STANDARD SUPPLY**

- Painted steel frame
- Cryogenic pump
- Electric motor
- Transmission by belts and pulleys
- Pulsation damper

**STANDARD ACCESSORIES**

- Suction flexible hose
- Return flexible hose
- Low pressure safety valve
- High pressure safety valve
- High pressure manual valve for venting
- Check valve
- Pressure gauge
- Pressure switch
- Temperature sensor for cool down
- Temperature sensor for cavitation
- Temperature sensor for leaks detection
- Phase separator (for Cold Converter installations)
- By-pass valve (for Cold Converter installations)

**OPTIONAL ACCESSORIES**

- High pressure pneumatic vent valve
- Configurable for breathable LOX
- Flushing system with nitrogen gas
- Electrical control panel
- 2 speed electric motor
- Motor suitable for VFD
- Complete automatic system available on demand

Average SKID weight: 420 kg

Package overall dimensions: 200 x 85 x 139 cm

**TEST AND CHECKS**

- Dimensional control of each mechanical component before assembly
- Performance test with LIN available for class and customer

**STANDARDS**

Designed according to:

- European Directive Machinery
- European Directive PED
- EIGA/IGC/CGA guidelines

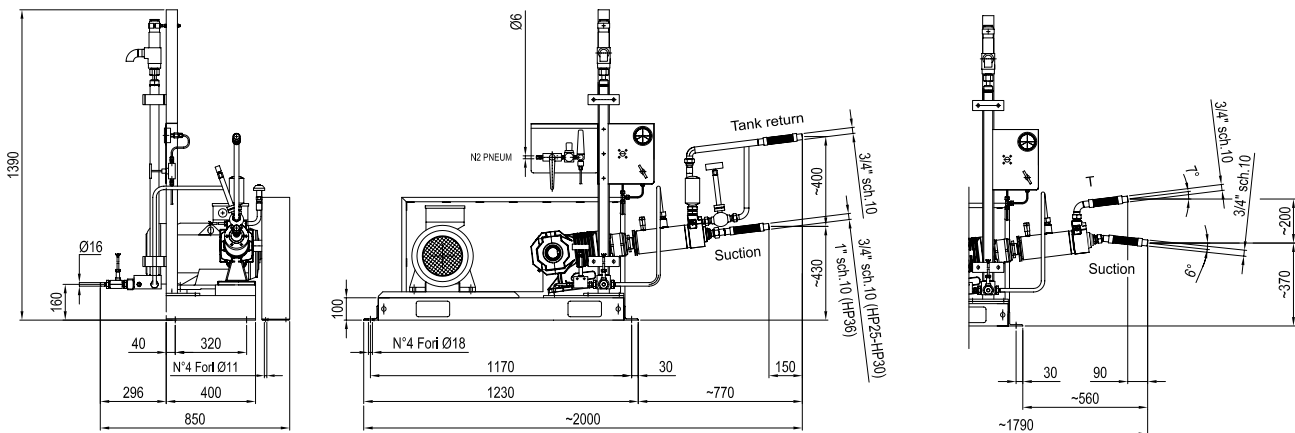
**GENERAL DIMENSIONS**

COLD CONVERTER CONFIGURATION

TERMOSYPHON CONFIGURATION



Certified quality management system