



Producto distribuido por

SDM
Oil & Gas

 (+51) 999 012777  ventas@sdm.pe

www.sdm.pe | Av. Galvez Barrenechea 274. San Isidro

CRYOGENIC CENTRIFUGAL PUMPS SGM SERIES FOR INDUSTRIAL GASES

TECHNICAL FEATURES

- Electric motor and gearbox transmission
- Mechanical seal in rulon
- Inducer to minimize required NPSH
- Low noise emission (< 80 dB)

APPLICATIONS

- Liquid transfer between storage tanks
- Industrial Processes

TRANSFERRED FLUIDS

- LIN, LOX, LAR, LCO₂, LN₂O

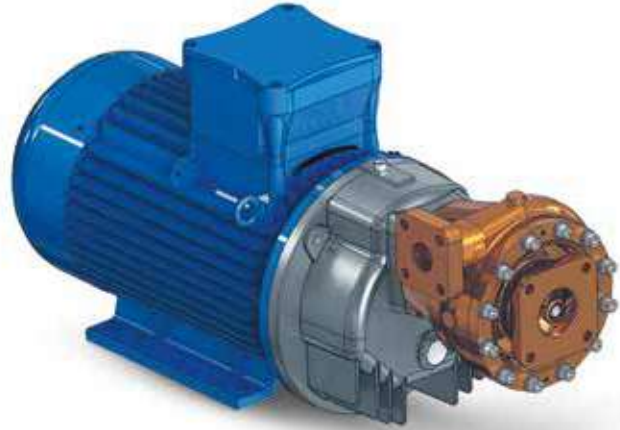

SGM SERIES PERFORMANCES

Model		SGM 160	SGM 185
Power installed (Motor frame)	Pm [kW]	11 - 15 - 18,5 (160)/22 (180) - 30 (200)	11 - 15 - 18,5 (160)/22 (180) - 30 - 37 (200)
Max operating speed (50 Hz)	rpm	7310	7510
Max suction pressure	P [bar]	6	6
Max allowable working pressure	MAWP [bar]	30	33
Max Head (50 Hz)	DH [m]	225	325
Max flow rate (50 Hz)	Q [lpm]	520	650

Data can be subjected to change

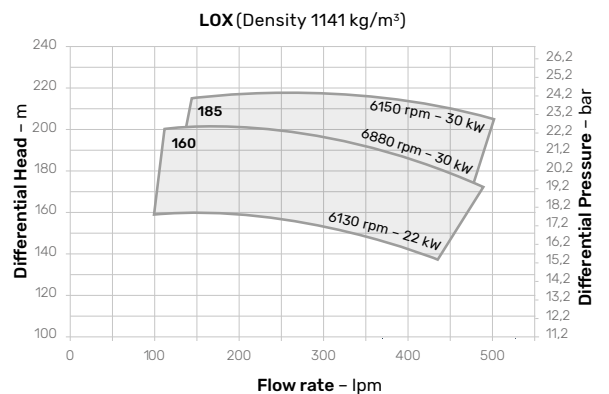
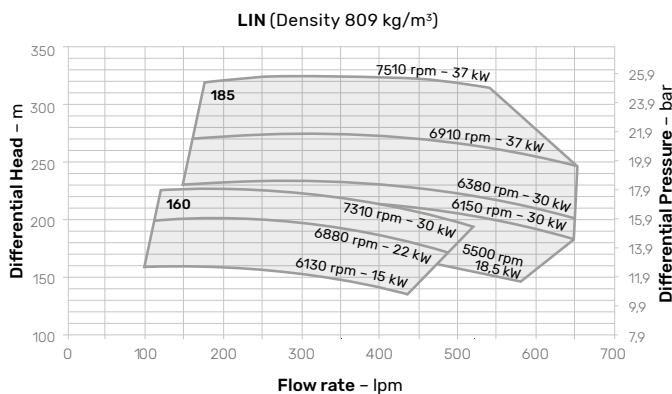

OPTIONAL ACCESSORIES

- Counter flanges
- Filter
- Flexible hose for suction and discharge line
- Leakage detection by temperature sensor
- Flushing system with nitrogen gas
- Temperature sensor for cooling down
- Electrical control panel
- Motor suitable for VFD
- Complete automatic system available on demand
- Mobile skid available on demand
- Temperature sensor of bearing casing

TEST AND CHECKS

- Dimensional control of each mechanical component before assembly
- Performance test with LIN available for class and customer

STANDARDS

Designed according to:

- European Directive
- EIGA/IGC/CGA guidelines

GENERAL DIMENSIONS

SGM 160

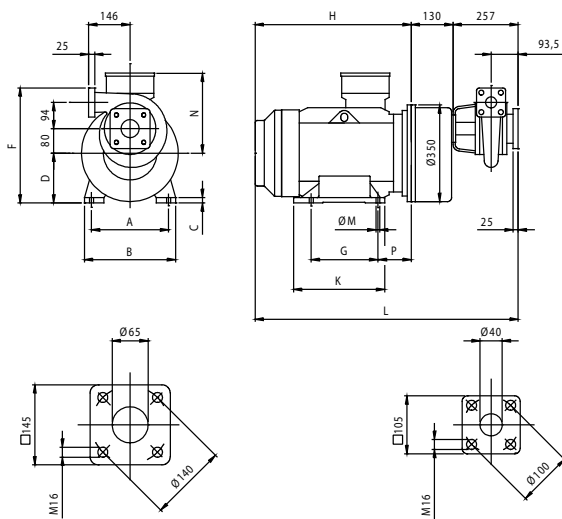

SGM 185

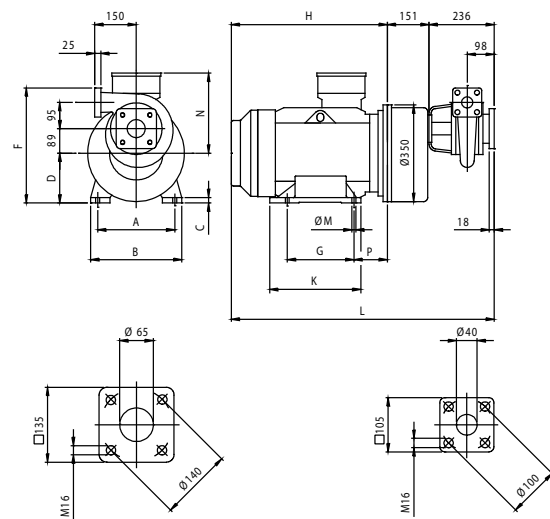

SGM 160

Available motor power [kW]	Motor size	A	B	C	D	F	G	H	K	L	M	N	P	Weight [kg]
11														
15	160	254	318	15	160	387	210	529	305	916	15	254	108	145
18,5								586		973				
22	180	279	350	20	180	407	241	618	340	1005	15	274	121	200
30	200	318	393	22	200	427	267	699	360	1086	19	315	133	270

SGM 185

Available motor power [kW]	Motor size	A	B	C	D	F	G	H	K	L	M	N	P	Weight [kg]
11														
15	160	254	318	15	160	397	210	529	305	916	15	254	108	145
18,5								586		973				160
22	180	279	350	20	180	417	241	618	340	1005	15	274	121	220
30	200	318	393	22	200	437	267	699	360	1086	19	315	133	270
37														

Data can be subjected to change



Certified quality management system