



Producto distribuido por

SDM
Oil & Gas

 (+51) 999 012777  ventas@sdm.pe

www.sdm.pe | Av. Galvez Barrenechea 274. San Isidro

CRYOGENIC CENTRIFUGAL PUMPS DSM SERIES

FOR LIQUEFIED NATURAL GAS (LNG)

TECHNICAL FEATURES

- Electric motor and direct transmission
- Mechanical seal in rulon
- Inducer to minimize required NPSH
- Low noise emission (< 80 dB)

APPLICATIONS

- Road trailers unloading, storage/iso-containers loading/unloading
- Bunkering
- Process and back-up operations, petrochemical industry applications

TRANSFERRED FLUIDS

- LNG



DSM SERIES** PERFORMANCES

Model		DSM 185	DSM 230
Power installed (Motor frame)	Pm [kW]	5,5 - 7,5 (132)	11 - 15 - 18,5 (160)
Max operating speed (50 Hz/60 Hz)	rpm	2950/3540	2950/3540
Max suction pressure	P [bar]	6	6
Max allowable working pressure	MAWP [bar]	23/33*	26
Max Head (50 Hz/60 Hz)	DH [m]	50/72	73/105
Max flow rate (50 Hz/60 Hz)	Q [lpm]	300/360	1250/1500

*Aluminium pump casing (23 bar) and bronze pump casing (33 bar)

**Special versions with high frequency VFD controlled motors are available

Data can be subjected to change

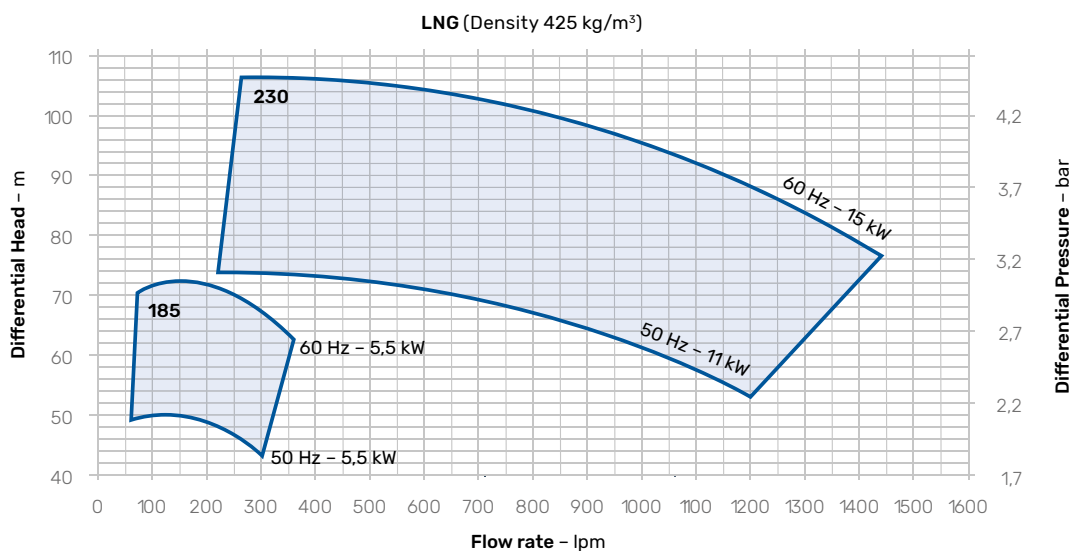

OPTIONAL ACCESSORIES

- Counter flanges
- Filter
- Flexible hoses for suction and discharge lines
- Leakage detection by temperature sensor
- Flushing system with nitrogen gas
- Temperature sensor for cooling down
- Electrical control panel
- Motor suitable for VFD
- Completely automated systems available on demand
- Mobile skid available on demand

TEST AND CHECKS

- Dimensional control of each mechanical component before assembly
- Performance test with LIN available for class and customer

STANDARDS

Designed according to:

- European Directive Machinery
- European Directive ATEX
- EIGA/IGC/CGA guidelines



GENERAL DIMENSIONS

DSM 185

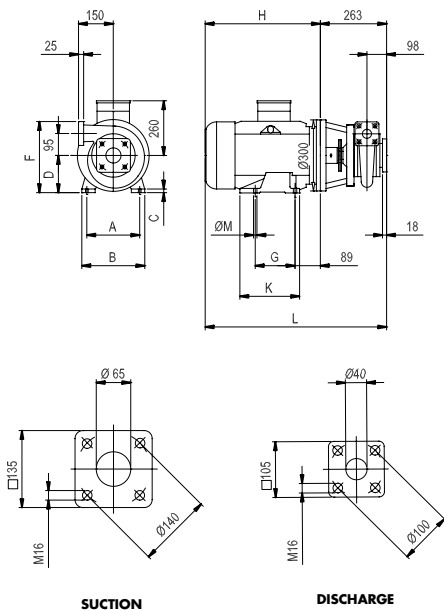

DSM 230

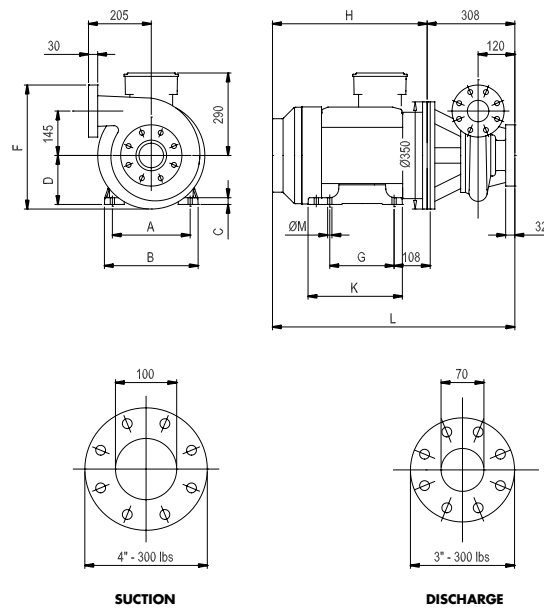

DSM 185

Available motor power [kW]	Motor size	A	B	C	D	F	G	H	K	L	M	Weight [kg]
5.5 / 7.5	132	216	272	13	132	280	140	425	222	688	12	120

DSM 230

Available motor power [kW]	Motor size	A	B	C	D	F	G	H	K	L	M	Weight [kg]
11 / 15 / 18.5	160	254	318	15	160	425	210	583	305	891	14	220

Data can be subjected to change



Certified quality management system