



Producto distribuido por

SDM
Oil & Gas

 (+51) 999 012777  ventas@sdm.pe

www.sdm.pe | Av. Galvez Barrenechea 274. San Isidro

CRYOGENIC CENTRIFUGAL PUMPS DSM SERIES FOR INDUSTRIAL GASES

TECHNICAL FEATURES

- Electric motor and direct transmission
- Mechanical seal in rulon
- Inducer to minimize required NPSH
- Low noise emission (< 80 dB)

APPLICATIONS

- Liquid transfer between storage tanks
- Process and backup pumps operations

TRANSFERRED FLUIDS

- LIN, LOX, LAR, LCO₂, LN₂O



DSM SERIES* PERFORMANCES

Model		DSM 160	DSM 185	DSM 230
Power installed (Motor frame)	Pm [kW]	4 (112)	5,5 - 7,5 (132)	11 - 15 - 18,5 (160)
Max operating speed (50 Hz/60 Hz)	rpm	2950/3540	2950/3540	2950/3540
Max suction pressure	P [bar]	6 - (25 LCO ₂ & LN ₂ O)	6 - (25 LCO ₂ & LN ₂ O)	6 - (25 LCO ₂ & LN ₂ O)
Max allowable working pressure	MAWP [bar]	30	33	26
Max Head (50 Hz/60 Hz)	DH [m]	37/53	50/72	73/105
Max flow rate (50 Hz/60 Hz)	Q [lpm]	210/250	300/360	800/1200

*Special versions with high frequency VFD controlled motors are available

Data can be subjected to change

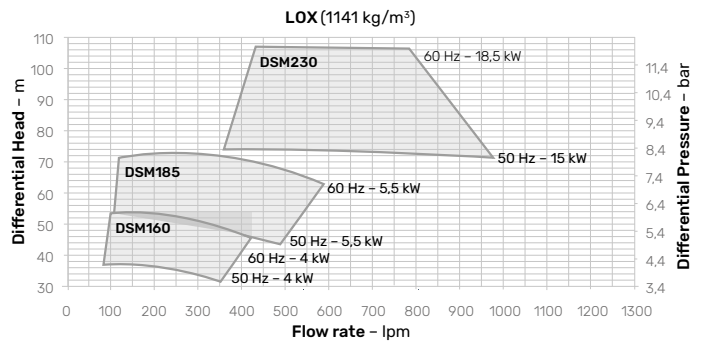
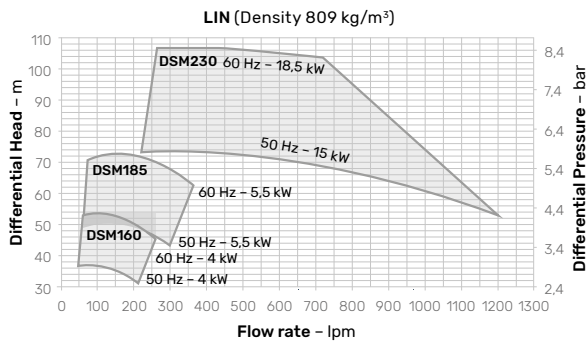

OPTIONAL ACCESSORIES

- Counter flanges
- Filter
- Flexible hose for suction and discharge lines
- Leakage detection by temperature sensor
- Flushing system with nitrogen gas
- Temperature sensor for cooling down
- Electrical control panel
- Motor suitable for VFD
- Complete automatic system available on demand
- Mobile skid available on demand
- Temperature sensor of bearing casing

TEST AND CHECKS

- Dimensional control of each mechanical component before assembly
- Running test of each pump with LIN before delivery

STANDARDS

Designed according to:

- European Directive
- EIGA/IGC/CGA guidelines

GENERAL DIMENSIONS

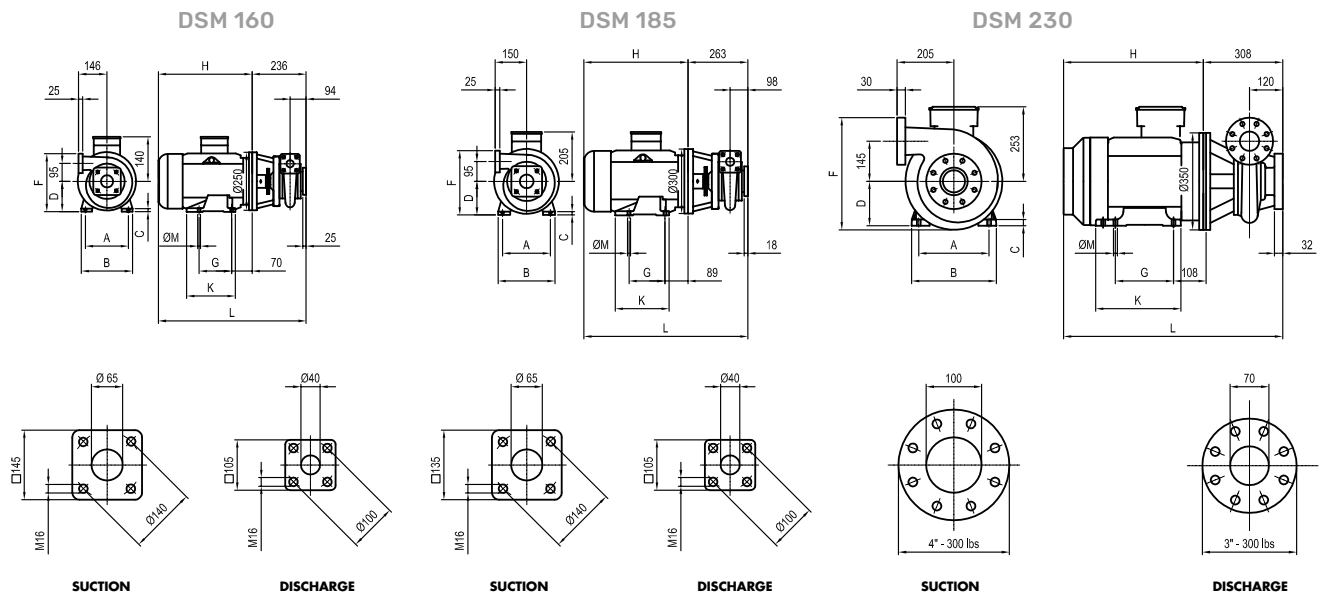

DSM 160

Available motor power [kW]	Motor size	A	B	C	D	F	G	H	K	L	M	Weight [kg]
4	112	190	228	13	112	258	140	350	222	586	12	70

DSM 185

Available motor power [kW]	Motor size	A	B	C	D	F	G	H	K	L	M	Weight [kg]
5,5	132	216	272	13	132	280	140	425	222	688	12	120
7,5												

DSM 230

Available motor power [kW]	Motor size	A	B	C	D	F	G	H	K	L	M	Weight [kg]
11	160	254	310	23	160	425	210	529	295	839	14	220
15								586		894		230
18,5												

Data can be subjected to change



Certified quality management system