



Producto distribuido por

SDM
Oil & Gas

 (+51) 999 012777  ventas@sdm.pe

www.sdm.pe | Av. Galvez Barrenechea 274. San Isidro

HOSE REEL TYPES

Manual Rewind
Hose reel with handle



Also available with chain transmission for bigger sizes.

Spring Rewind
Hose reel with automatic spring-loaded rewind system



Suitable for retraction of hoses up to 25 m in DN 50 mm.

Electric Rewind
Hose reel with electric motor



Electric motors available:
AC = 230 / 400 V
DC = 12 V / 24 V
Optionally with ATEX certified motors.

Hydraulic Rewind
Hose reel with hydraulic motor



The motor is always provided with levers to operate.

Pneumatic Rewind
Hose reel with pneumatic motor



Optionally available with 'ON/OFF' kit to operate the hose reel.

Additional Product: Bonding Reel
Reel with spring rewind mechanism



Frame available in polyester powder coated steel, UV resistant or stainless steel and any colour.
High visibility grounding cable, up to 30m, DN 6mm and different types of clamps.

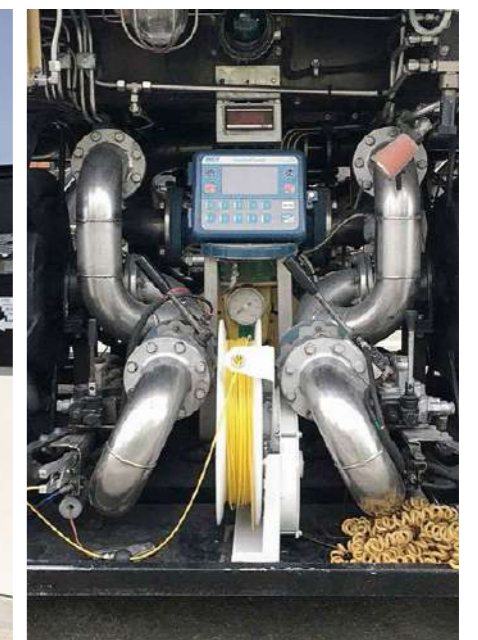
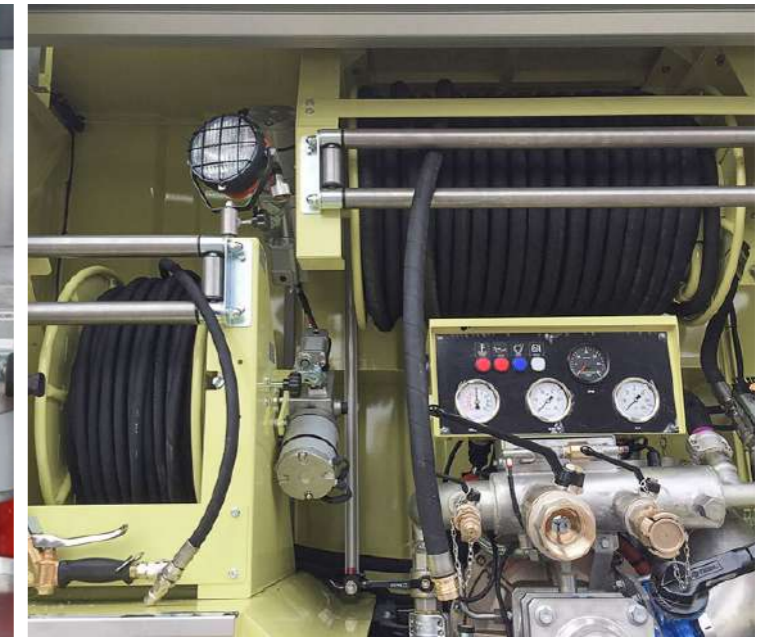
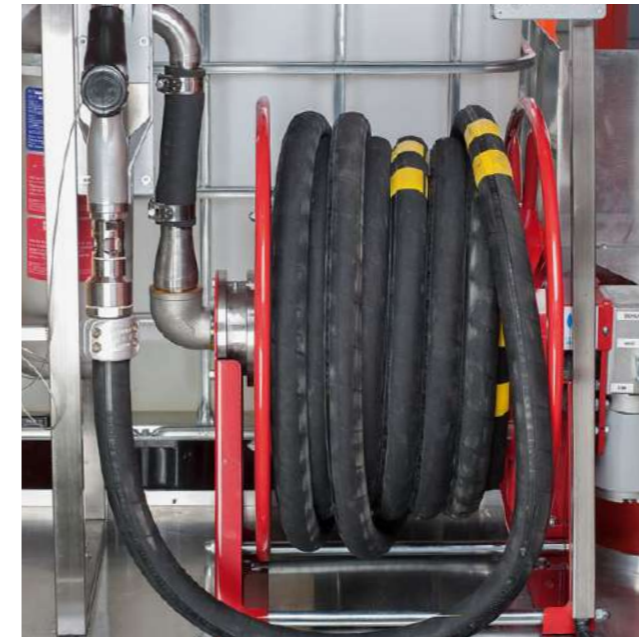
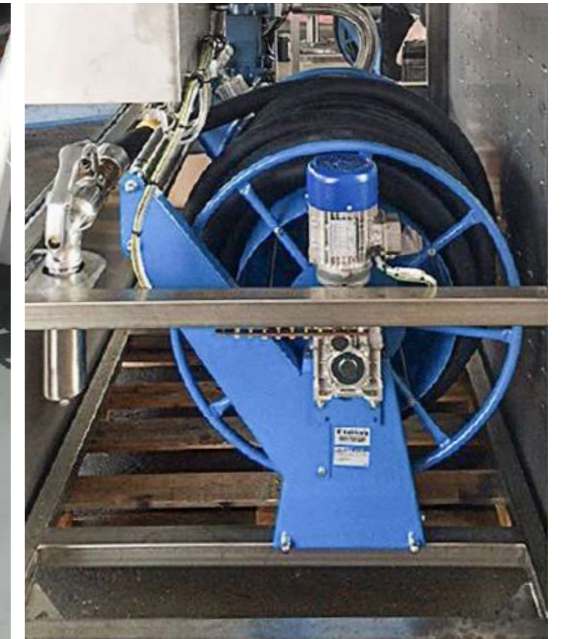

ELAFLEX Hose Reels are supplied as a complete customised package incl. our hoses, couplings and nozzles.

Hose Reels 'Modular Line G and GB 25/38' as manual or motorised, used for retraction of Elaflex hoses up to 40 m in max. DN 38 or 70 m in max. DN 25. It can be supplied with different rewind systems (manual, electric, hydraulic and pneumatic), resistant materials and swivel joints.

Suitable for a wide range of media, e.g. gasoline, diesel, aviation fuels, urea solution (AdBlue®), detergents, solvents, oils, water, gases and others. For example: HD 38 with ZV 400 for ship refuelling.

Standard versions are supplied with open disks.

CUSTOMISED VERSION

Drum diameter and disc distance can be customised to meet special requirements.

MATERIALS

Frame: available in polyester powder coated carbon steel, UV resistant (on request: cataphoresis treatments or zinc plated) or stainless steel (AISI 304 or AISI 316L).

Wet parts: available in carbon steel or stainless steel (AISI 304 or AISI 316L).

Swivel joint: available in carbon steel (zinc plated), brass or stainless steel (AISI 303 / AISI 316L), in 90° or straight shape*).

Working pressure up to 200 bar*).

Temperature range -40° to +120° C*).

COLOURS



DIMENSIONS

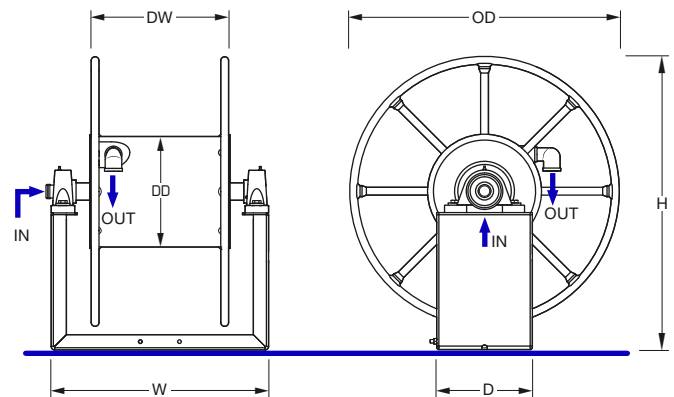

Recommended Hose	Connections	Drum Diameter	Disc Diameter	Distance btw the disks	Dimensions	Weight	Standard Part Number	
max. Length	max. DN	IN / OUT	DD Ø mm	OD Ø (mm)	DW (mm)	W x D x H (mm)	kg	
35 m	DN 25	1" bsp female / 1" bsp female	310	620	280	500x620x675	-	HR ML GB 25 L35
18 m	DN 38	1½" bsp female / 1½" bsp female	310	620	280	500x620x690	-	HR ML GB 38 L18
70 m	DN 25	1" bsp female / 1" bsp female	310	750	380	600x750x805	-	HR ML G 25 L70
40 m	DN 38	1½" bsp female / 1½" bsp female	310	750	380	600x750x820	-	HR ML G 38 L40

1) Hose Reels dimensions without swivel joint and rewind system.

2) Please contact our sales team to check capacity when smaller hose diameters are required.

SWIVEL JOINTS

90° SWIVEL JOINT (1)

DN 1" available in zinc plated carbon steel or stainless steel AISI 303 or brass

DN 1½" available in zinc plated carbon steel

STRAIGHT SWIVEL JOINT (2)

DN 1" available in zinc plated carbon steel
stainless steel AISI 316 L

DN 1½" available in zinc plated carbon steel

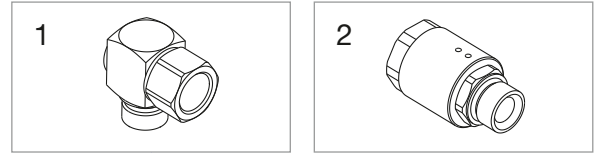

REWIND SYSTEMS

MANUAL REWIND (3)

- with lateral handle
- direct drive

options:

- mechanical lock
- friction break
- chain transmission

HYDRAULIC REWIND (4)

- hydraulic motor with operational levers and hydraulic lock
- direct drive

options:

- speed control kit
- chain transmission

THREE PHASE ELECTRIC REWIND (5)

- electric motor 230/400V
- direct drive

options:

- control panel kit
- control panel kit with remote control
- mono phase inverter kit
- chain transmission

on request:

- ATEX 2GD or 3GD

ELECTRIC REWIND (6)

- electric motor 12V or 24V
- direct drive

options:

- control panel kit
- kit on/off
- friction break for "E" motor
- chain transmission

on request:

- ATEX 2GD or 3GD

PNEUMATIC REWIND (7)

- pneumatic motor
- direct drive

options:

- kit on/off
- chain transmission

ACCESSORIES

HOSE GUIDE KIT (8)

AUTOMATIC HOSE GUIDE KIT (9)

KIT FOR DISKS CLOSURE (10)

(recommended for motorised systems)

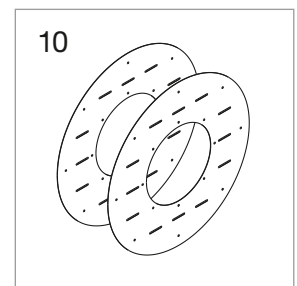
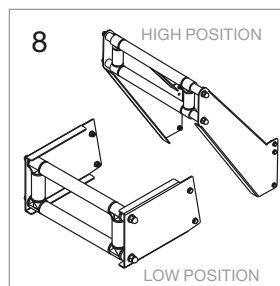
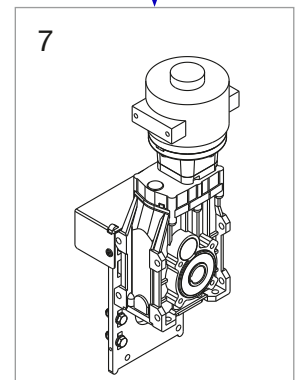
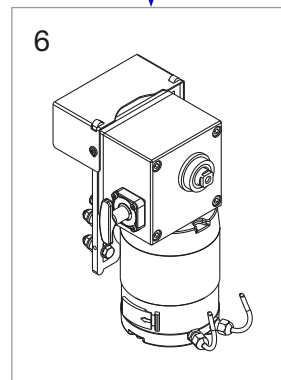
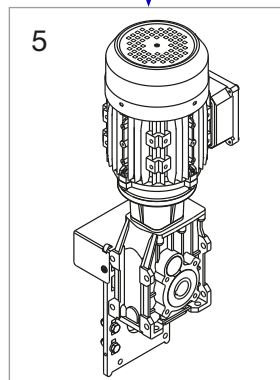
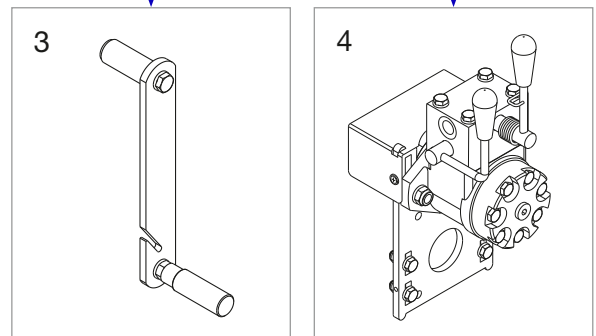
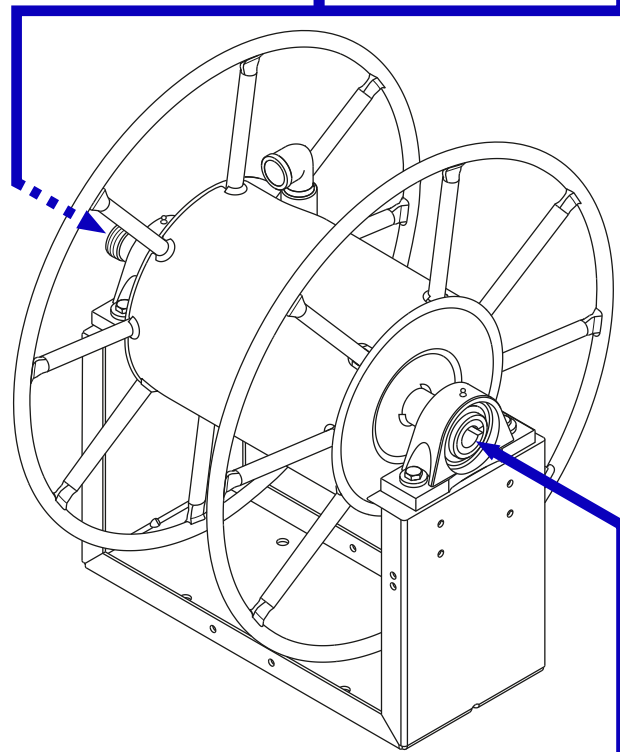

ELAFLEX Hose Reels are made from our own production and supplied as a complete package incl. hoses, couplings and nozzles.

Hose Reels 'Modular Line M' are used for retraction of Elaflex hoses up to 50 m in max. DN 25.

It can be supplied with different rewind systems (manual, electric, hydraulic and pneumatic), resistant materials and swivel joints.

The OUT connection is placed outside the disks giving the drum more space to distribute the hose layers.

Suitable for a wide range of media, e.g. gasoline, diesel, aviation fuels, urea solution (AdBlue®), detergents, solvents, oils, water, gases and others. For example: Slimline 'SL' 25 with ZVA 25 for tank trucks with motor rewind.

Standard version is supplied with closed disks.

CUSTOMISED VERSION

Drum diameter and disc distance can be customised to meet special requirements.

MATERIALS

Frame available in polyester powder coated carbon steel UV resistant (on request: cathaphoresis treatments or zinc plated) or stainless steel (AISI 304 or AISI 316 L).

Wet parts available in carbon steel or stainless steel (AISI 304 or AISI 316 L).

Swivel joint available in zinc plated carbon steel, brass or stainless steel (AISI 303/AISI 316 L), in 90° or straight shape*).

Working pressure up to 200 bar*).

Temperature range -40° to +120° C*).

*) depending on materials

COLOURS



RAL 5017



RAL 3002



Special Colours
(on request)



DIMENSIONS

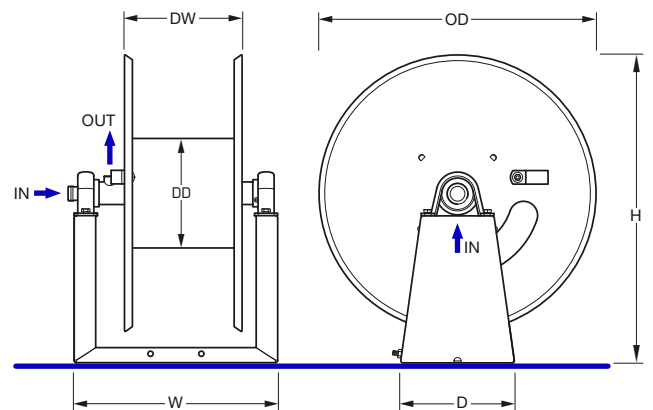

Recommended Hose		Connections	Drum Diameter	Disc Diameter	Distance btw the disks	Dimensions	Weight	Standard Part Number
max. Length	max. DN	IN / OUT	DD Ø mm	OD Ø (mm)	DW (mm)	W x D x H (mm)	kg	Type
20 m	DN 25	1" bsp male / 1" bsp female	194	490	280	360x490x545	-	HR ML M 25 L20
30 m	DN 25	1" bsp male / 1" bsp female	194	490	380	460x490x545	-	HR ML M 25 L30
40 m	DN 25	1" bsp male / 1" bsp female	194	490	480	560x490x545	-	HR ML M 25 L40
50 m	DN 25	1" bsp male / 1" bsp female	194	490	580	660x490x545	-	HR ML M 25 L50

1) Hose Reels dimensions without swivel joint and rewind system.

2) Please contact our sales team to check capacity when smaller hose diameters are required.

SWIVEL JOINTS

90° SWIVEL JOINT (1)

DN 1" available in zinc plated carbon steel or stainless steel AISI 303 or brass

STRAIGHT SWIVEL JOINT (2)

DN 1" available in zinc plated carbon steel or stainless steel AISI 316 L

REWIND SYSTEMS

MANUAL REWIND (3)

- with lateral handle
- direct drive

options:

- mechanical lock
- friction break

HYDRAULIC REWIND (4)

- hydraulic motor with operational levers and hydraulic lock
- direct drive

options:

- speed control kit

THREE PHASE ELECTRIC REWIND (5)

- electric motor 230/400V
- direct drive

options:

- control panel kit
- control panel kit with remote control
- mono phase inverter kit

on request:

- ATEX 2GD or 3GD

ELECTRIC REWIND (6)

- electric motor 12V or 24V
- direct drive

options:

- control panel kit
- kit on/off
- friction break for 'E' motor

on request:

- ATEX 2GD or 3GD

PNEUMATIC REWIND (7)

- pneumatic motor
- direct drive

option:

- kit on/off

ACCESSORIES

HOSE GUIDE KIT (8)

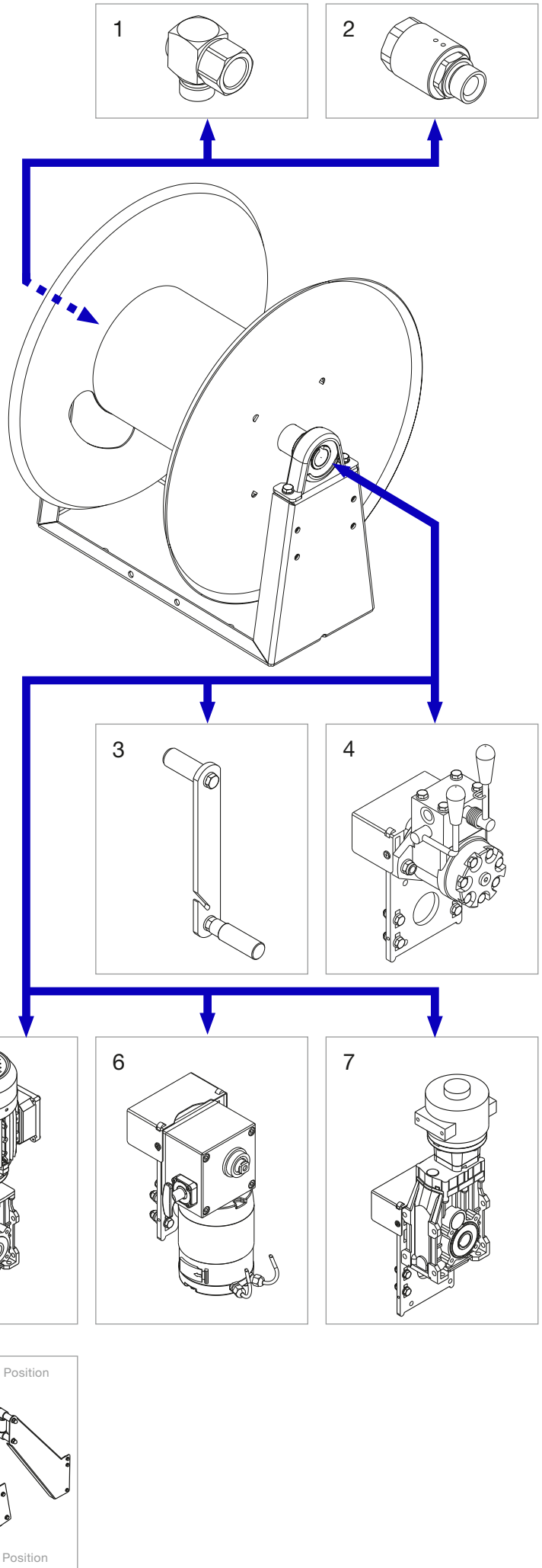

Our 'HR' Hose Reel Packages are supplied with our bespoke hoses, couplings or nozzles.

- all components made by Elaflex – one supplier, one system, one liability, one price
- delivered as complete tested system including hoses, couplings and nozzles
- high quality standard, longevity, short lead times
- modular designed, various materials and colours to suit space, media and requirements

HR 'Compact Line' is fitted with spring rewind system and integrated static hose guide.

HR 'Modular Line' comes with various rewind systems (manual, electric, hydraulic, pneumatic).

Commonly used for applications such as:

- Aviation
- Marina/Ports/Ships
- Depots/Petrol Stations
- Trucks

HEAVY DUTY (HD) SPRING REWIND HOSE REELS

HR 'Compact Line HD 25'



Suitable for hose sizes DN 13 - 25
(e.g. up to 40 m for DN 25)

HR Information 01E

or

HR 'Compact Line HD 50'



Suitable for hose sizes DN 32 - 50
(e.g. up to 25 m for DN 50)

HR Information 02E

+



ECONOMY SPRING REWIND HOSE REELS

HR 'Compact Line T'



Suitable for hose sizes DN 13 - 25
(e.g. up to 8 m for DN 25)

HR Information 03E

or

HR 'Compact Line B'



Suitable for hose sizes DN 13 - 25
(e.g. up to 20 m for DN 25)

HR Information 04E

+



Also available:
Vapour Recovery
Hose Reels
HR Information 07E

MODULAR REWIND HOSE REELS

(available with manual, electric, hydraulic, pneumatic rewind system)

HR 'Modular Line G + GB'



Suitable for hose sizes DN 25 - 200
(e.g. up to 40 m for DN 38)

HR Information 05E

or

HR 'Modular Line M'



Suitable for hose sizes DN 13 - 25
(e.g. up to 50 m for DN 25)

HR Information 06E

+

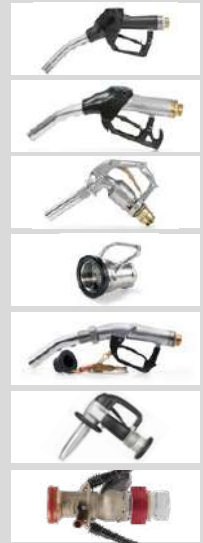

Special Packages

STORAGE HOSE REELS

For Storage Only



Suitable for hoses DN 13 - 250,
for a safe and clean storage

All Types of Rewind Systems

BONDING REELS

Earthing and Bonding



Highly visible bonding cable, up to 30m,
DN 6 mm, different types of clamps

Spring Rewind

For further details and information, please contact our Sales Team.

